

Cree® XLamp® XR-C LED

Data Sheet

The XLamp XR-C LED gives lighting designers the flexibility and performance to create the next generation of LED lighting products. XLamp XR-C LEDs retain the industry-leading XLamp package characteristics, such as electrically neutral thermal path, reflow-solderable package, floating lens, and support for a wide range of drive currents.

Cree XLamp LEDs bring high performance and quality to many lighting applications, including portable lighting and flashlights, transportation, outdoor and industrial, signaling, architectural and entertainment/advertising installations.

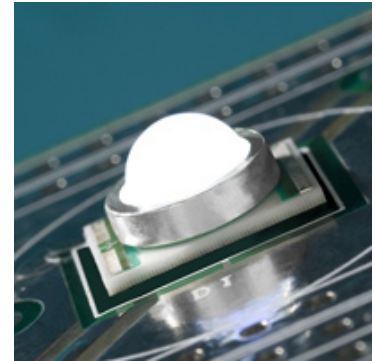

FEATURES

- Full range of white: 2600 K to 10,000 K CCT
- Drive currents: 125 to 500 mA
- Low thermal resistance: 12°C/W
- Max junction temperature: 145°C
- Industry-leading JEDEC standard pre-qualification testing
- Reflow solderable – JEDEC J-STD-020C compatible
- Electrically neutral thermal path
- RoHS-compliant
- Lumen maintenance of greater than 70% after 50,000 hours

Table of Contents

Flux Characteristics ($T_j = 25^\circ\text{C}$).....	2
Characteristics	2
Relative Spectral Power	3
Photometric Output vs. Junction Temperature ($I_f = 350\text{ mA}$)	3
Electrical Characteristics ($T_j = 25^\circ\text{C}$).....	4
Thermal Design	4
Relative Intensity vs. Current ($T_j = 25^\circ\text{C}$).....	5
Typical Spatial Radiation Pattern	5
Reflow Soldering Characteristics	6
Notes.....	7
Mechanical Dimensions ($T_A = 25^\circ\text{C}$)	8
Tape and Reel	9
Dry Packaging and Packaging	10

Flux Characteristics (T_j = 25°C)

Color	Correlated Color Temperature (CCT)		Typical Luminous Flux		
	Min.	Max.	@ 125 mA	@ 350 mA	@ 500 mA
White	5000 K	10000 K	25 lm	60 lm	78 lm
	3700 K	5000 K	25 lm	60 lm	78 lm
	2600 K	3700 K	23 lm	54 lm	70 lm

Notes:

- Cree maintains a tolerance of +/- 7% on flux and power measurements.
- Typical CRI for white 3700 K – 10,000 K CCT is 75.
- Typical CRI for white 2600 K – 3700 K CCT is 80.

Characteristics

Characteristics	Unit	Minimum	Typical	Maximum
Thermal Resistance, junction to solder point	°C/W		12	
Viewing Angle (FWHM)	degrees		90	
Temperature coefficient of voltage	mV/°C		-4.0	
ESD Classification (HBM per Mil-Std-883D)			Class 2	
DC Forward Current	mA			500
Forward Voltage (@ 125 mA)	V		3.2	
Forward Voltage (@ 350 mA)	V		3.5	4.0
Forward Voltage (@ 500 mA)	V		3.6	
LED Junction Temperature	°C			145
Operating Temperature	°C	-40		85

Relative Spectral Power

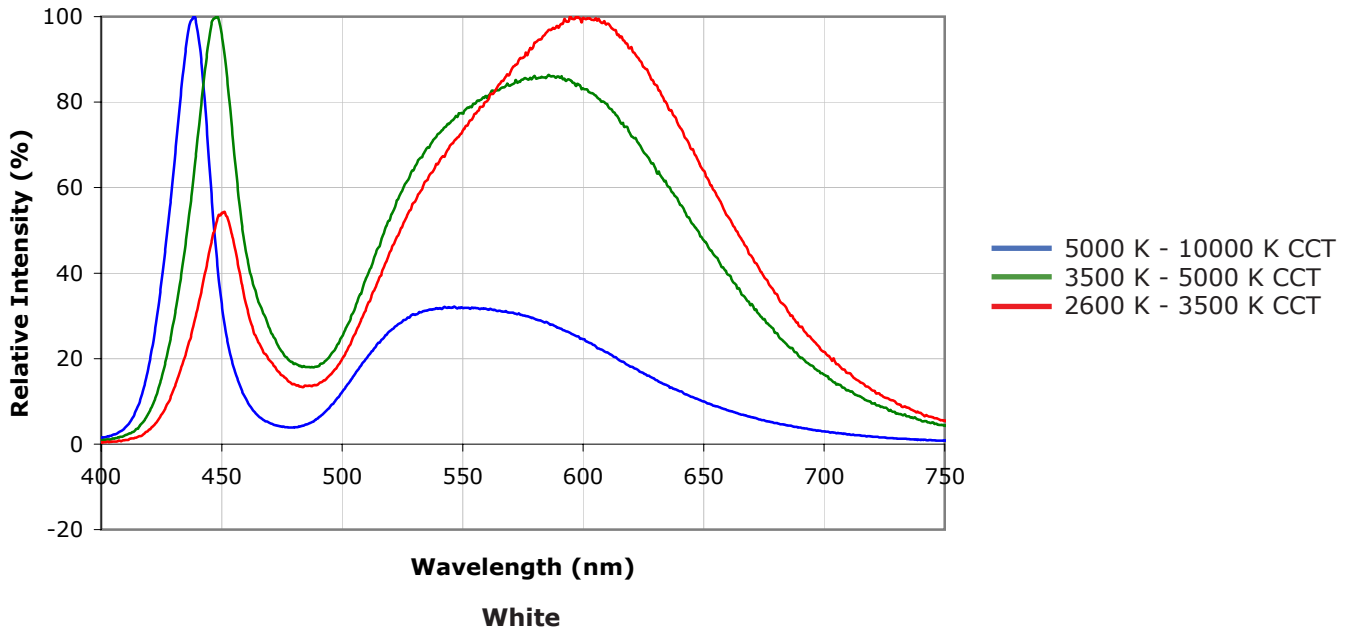

Photometric Output vs. Junction Temperature ($I_F = 350$ mA)

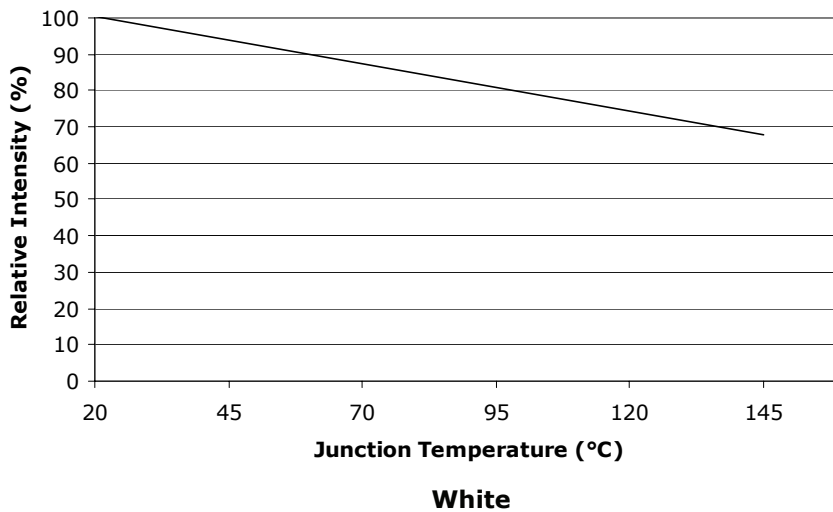

Electrical Characteristics ($T_j = 25^\circ\text{C}$)

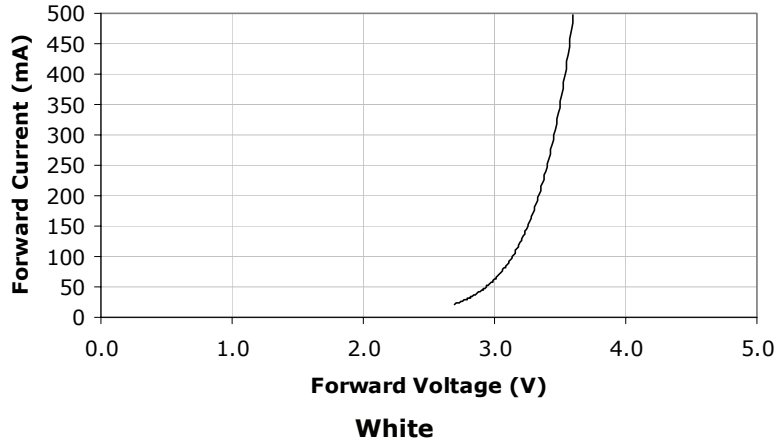

Thermal Design

The maximum forward current is determined by the thermal resistance between the LED junction and ambient. Given an existing thermal resistance of 12°C/W between the junction and the solder point, it is crucial for the end product to be designed in a manner that minimizes the thermal resistance from the solder point to ambient in order to optimize lamp life and optical characteristics.

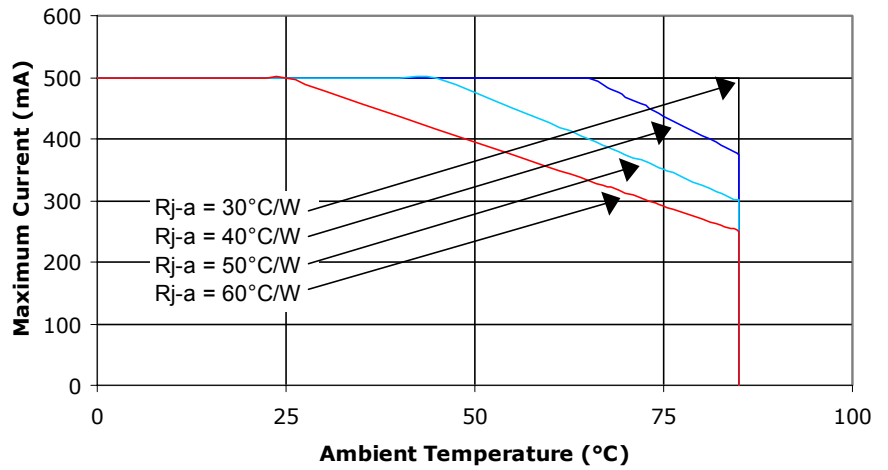

Relative Intensity vs. Current ($T_j = 25^\circ\text{C}$)

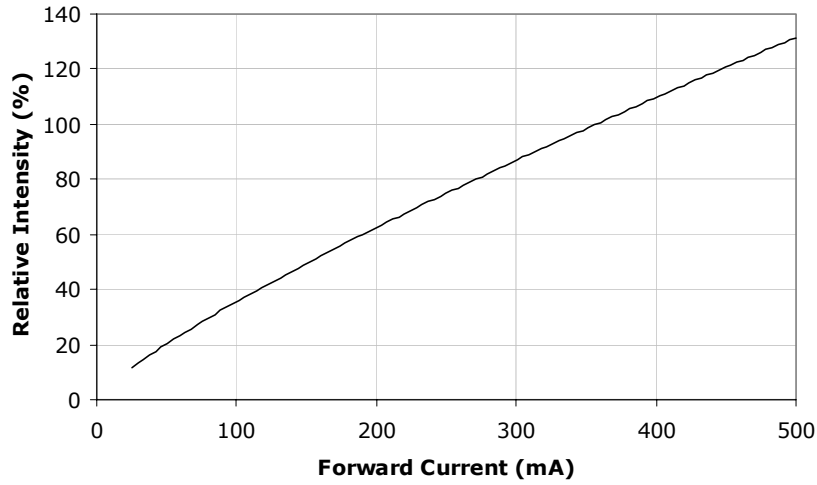

Typical Spatial Radiation Pattern

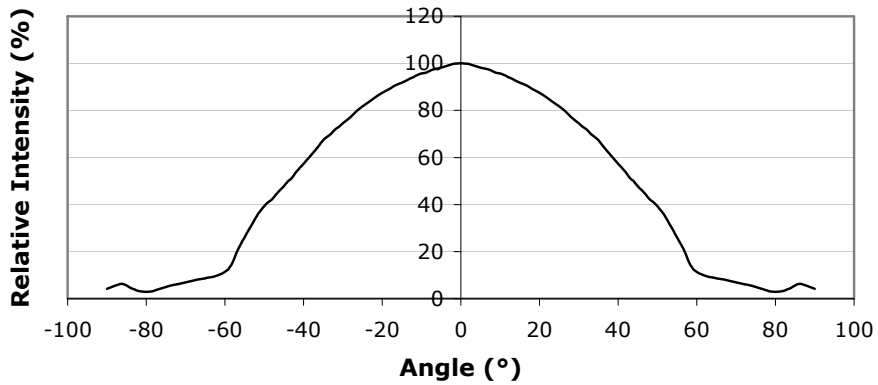

Reflow Soldering Characteristics

The following reflow soldering profiles are provided for reference. Cree recommends that users follow the recommended solder paste profile provided by the manufacturer of the solder paste used. Cree XLamp LEDs are compatible with JEDEC J-STD-020C.

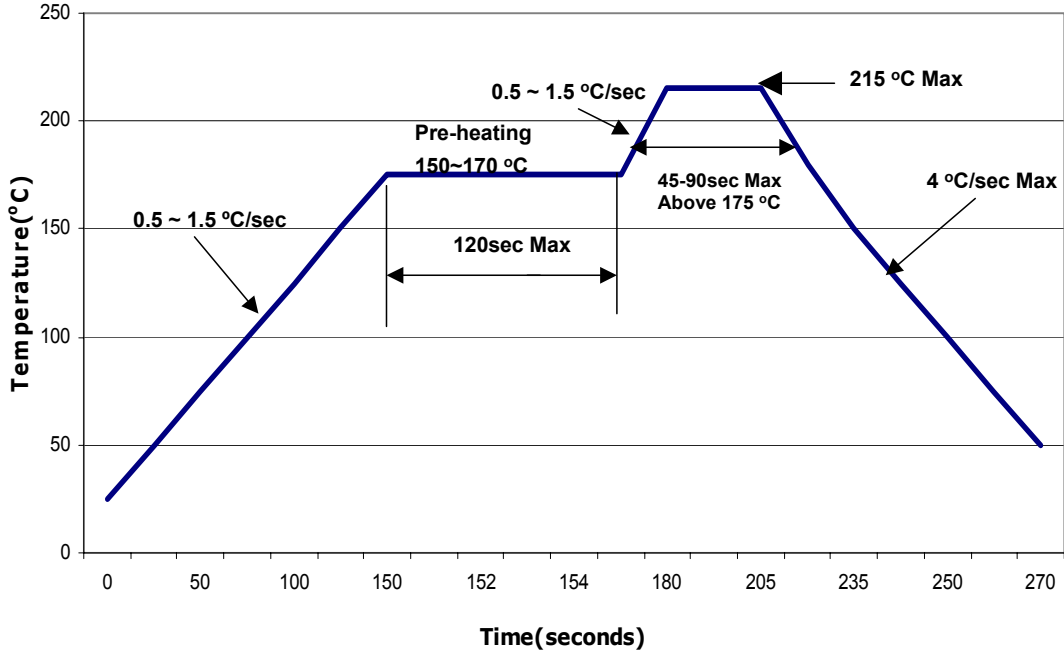

Lead-Based Solder Profile

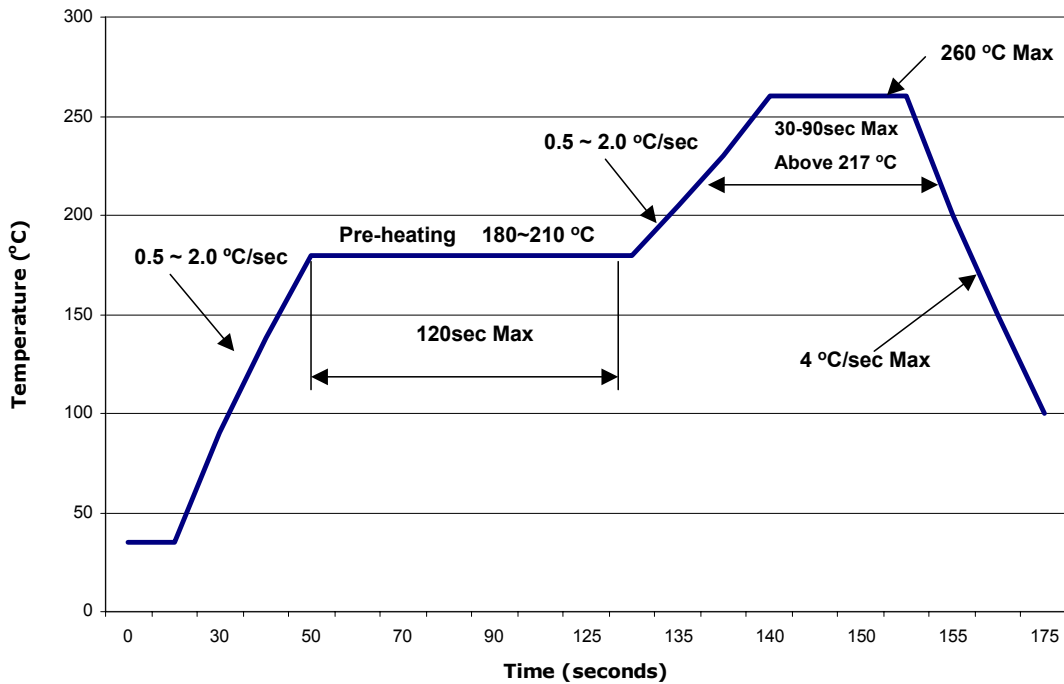

Lead-Free Solder Profile

Notes

Lumen Maintenance Projections

Based on internal long-term reliability testing and standardized forecasting methods, Cree projects XLamp LEDs to maintain an average of 70% lumen maintenance after 50,000 hours, provided the LED junction temperature is maintained at or below 80°C.

Please read the XLamp Reliability application note for more details on Cree’s lumen maintenance testing and forecasting. Please read the XLamp Thermal Management application note for details on how thermal design, ambient temperature, and drive current affect the LED junction temperature.

Moisture Sensitivity

If XLamp LEDs are exposed to excessively moist environments before soldering, damage to the LED may occur during the soldering operation. To avoid this damage, exposed lamps must be baked at 80°C for 24 hours. The following derating table (excerpted from JEDEC J-STD-033 Table 7-1 - Recommended Equivalent Total Floor Life) defines the maximum time (in days) under various humidity and temperature conditions that a lamp may be exposed before requiring baking.

Temperature	Maximum Percent Relative Humidity						
	30%	40%	50%	60%	70%	80%	90%
30°C	9	5	4	3	1	1	1
25°C	12	7	5	4	2	1	1
20°C	17	9	7	6	2	2	1

Within one hour of baking or one hour of opening the original packaging, XLamp LEDs must be stored according to Section 5.3 (Safe Storage) of JEDEC J-STD-033. Otherwise, these parts must be baked again at 80°C for 24 hours and resealed properly within one hour of baking. Do not bake parts at temperatures higher than 80°C, as damage to the reel will occur.

RoHS Compliance

The levels of environmentally sensitive, persistent biologically toxic (PBT), persistent organic pollutants (POP), or otherwise restricted materials in this product are below the maximum concentration values (also referred to as the threshold limits) permitted for such substances, or are used in an exempted application, in accordance with EU Directive 2002/95/EC on the restriction of the use of certain hazardous substances in electrical and electronic equipment (RoHS), as amended through April 21, 2006.

Vision Advisory Claim

Users should be cautioned not to stare at the light of this LED product. The bright light can damage the eye.

Mechanical Dimensions ($T_A = 25^\circ\text{C}$)

All measurements are $\pm 0.1\text{mm}$ unless otherwise indicated.

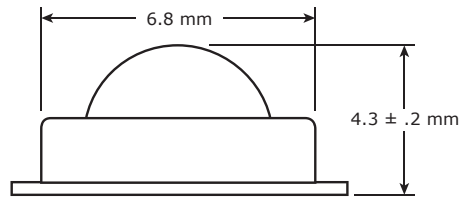
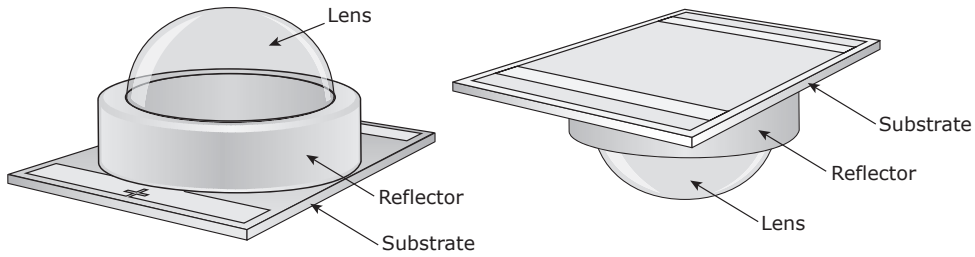

Side View

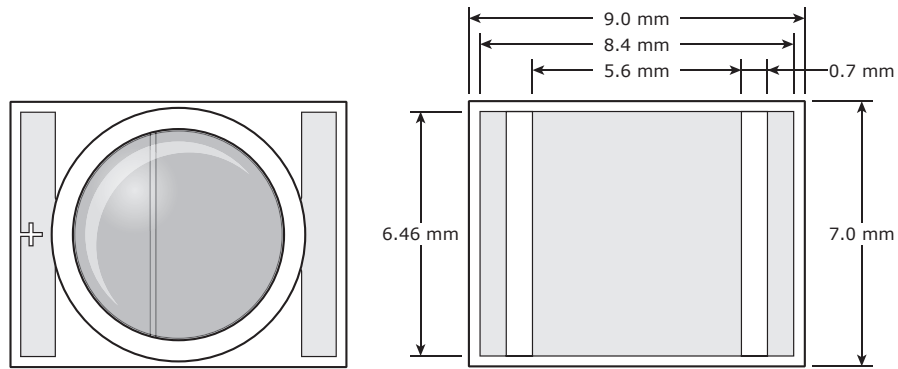

Top View

Bottom View

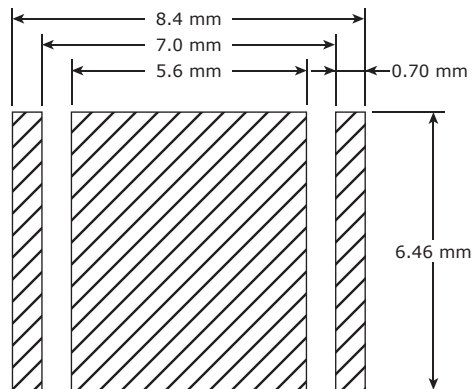

Recommended PC Board Solder Pad

Tape and Reel

All dimensions in mm.

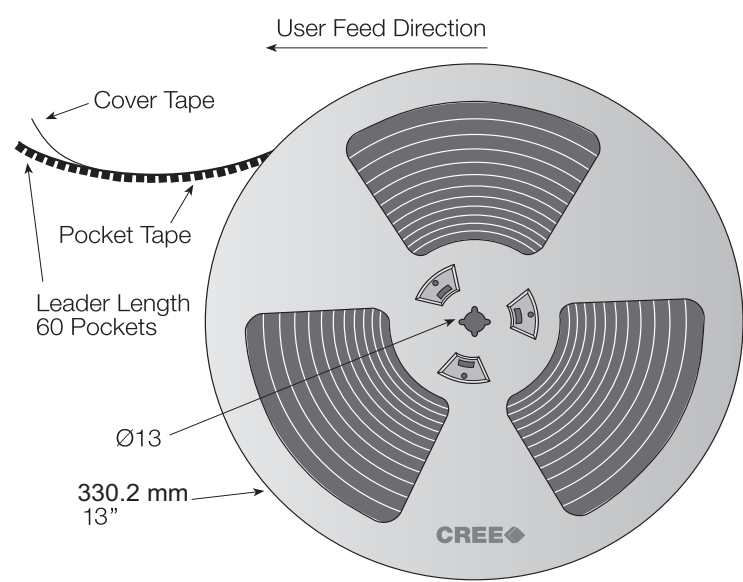
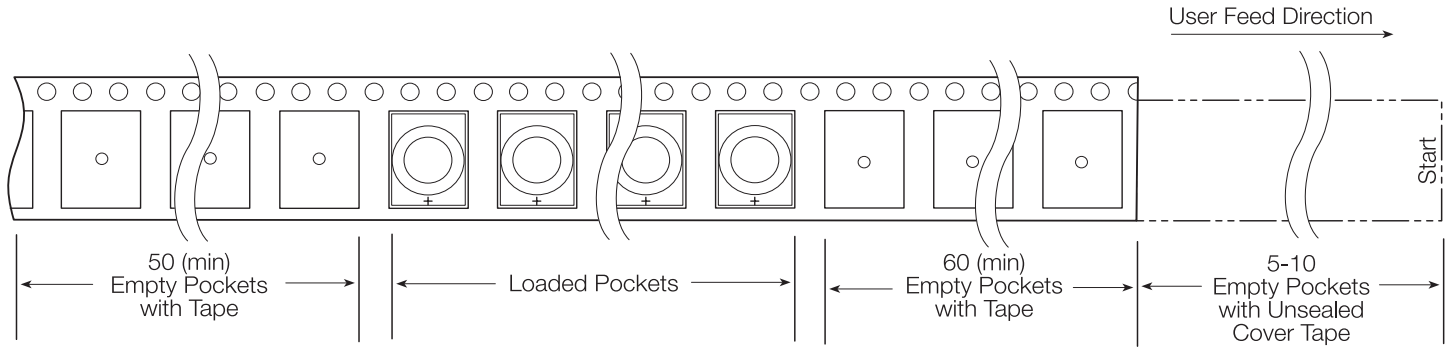
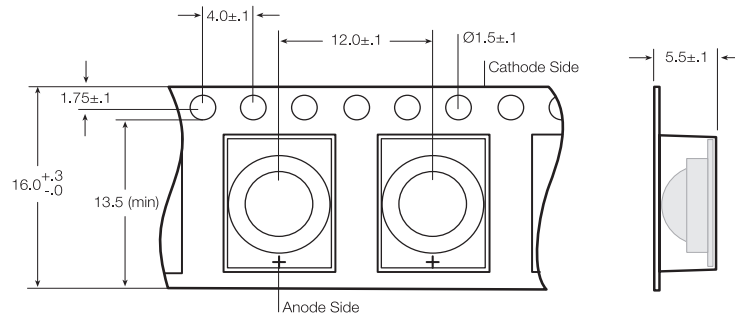
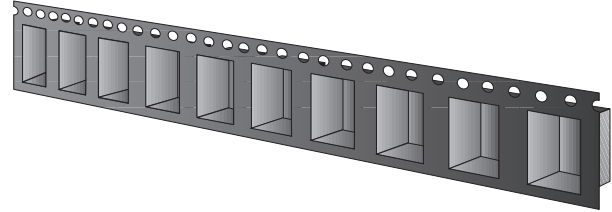
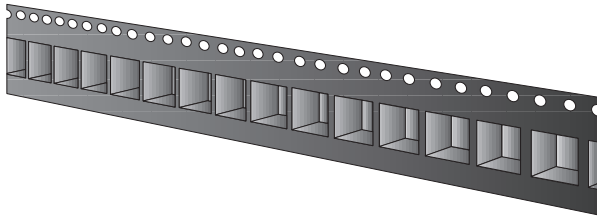

Dry Packaging and Packaging

