

Cree® XLamp® XR LED Data Sheet

Cree XLamp LEDs combine the brightness of power LED chips with a rugged package capable of operating in excess of one watt. Cree XLamp LEDs lead the solid-state lighting industry in brightness while providing a reflow-solderable design that is optimized for ease of use and thermal management. Lighting applications featuring XLamp LEDs maximize light output and increase design flexibility, while minimizing environmental impact.

Cree XLamp LEDs bring the power of brightness to a wide range of lighting and backlighting applications including portable lighting and flashlights, computer and television screens, signaling, architectural, landscaping and entertainment/advertising installations.



FEATURES

- Full range of drive currents up to 700 mA
- Surface-mount technology — reflow solderable
- Wide range of colors
 - White, Royal Blue, Blue, Cyan, Green, Amber, Red-Orange and Red
- Low operating voltage
- Electrically neutral thermal path
- RoHS-compliant — lead-free
- Integrated lens
- Small footprint — 7.0 mm x 9.0 mm
- ESD > 2000 V
- Lumen Maintenance of greater than 70% on average after 50,000 hours

Table of Contents

Flux Characteristics ($T_j = 25^\circ\text{C}$).....	2
Characteristics	2
Relative Spectral Power	3
Typical Electrical Characteristics ($T_j = 25^\circ\text{C}$)	4
Thermal Design.....	4
Typical Relative Intensity vs. Current ($T_j = 25^\circ\text{C}$)	5
Typical Spatial Radiation Pattern	5
Photometric Output vs. Junction Temperature ($I_f = 350\text{ mA}$)	6
Reflow Soldering Characteristics	7
Notes.....	8
Mechanical Dimensions ($T_A = 25^\circ\text{C}$)	9
Tape and Reel	10
Dry Packaging and Packaging	11

Flux Characteristics (T_j = 25°C)

Color	Dominant wavelength (nm)		Typical Luminous or Radiant flux @ 350 mA
	Min.	Max.	
Royal Blue	455	465	255 mW
Blue	465	475	15 lm
Cyan	500	510	45 lm
Green	520	535	52 lm
Amber	585	595	42 lm
Red-Orange	610	620	49 lm
Red	620	635	40 lm

Color	CCT (K)		Typical Luminous or Radiant flux @ 350 mA
	Min.	Max.	
Global White	5000	10000	51 lm
White	5000	10000	46 lm
	3500	5000	43 lm
	2600	3500	37 lm

Note: Cree maintains a tolerance of +/- 7% on flux and power measurements.

Characteristics

Characteristics	Unit	Min	Typical	Max
Thermal Resistance, junction to solder point (white, royal blue, blue, cyan, green)	°C/W		8	
Thermal Resistance, junction to solder point (amber, red-orange, red)	°C/W		15	
Viewing angle (FWHM)	degrees		100	
Temperature coefficient of voltage (royal blue, blue, cyan, green, white)	mV/°C		-3.0 to -2.8	
Temperature coefficient of voltage (amber, red-orange, red)	mV/°C		-3.2 to -3.0	
ESD Classification (HBM per Mil-Std-883D)			Class 2	
DC Forward Current (royal blue, blue, cyan, green, red-orange, red, white > 4444K)	mA			700
DC Forward Current (amber, white < 4444K)	mA			350
DC Pulse Current (white, royal blue, blue, cyan, green @ 1 kHz, 10% duty cycle)	A			1.8
DC Pulse Current (amber, red-orange, red @ 1 kHz, 10% duty cycle)	A			1.0
Reverse Voltage	V			5
Forward Voltage @ 350 mA (royal blue, blue, cyan, green, white)	V		3.4	4.0
Forward Voltage @ 350 mA (amber, red-orange, red)	V		2.25	3.0
LED Junction Temperature	°C			145
Operating Temperature	°C	-40		85

For details on Cree's procedures for sorting, binning and labeling and a list of standard order codes, see the application note [Cree XLamp XR LED Binning and Labeling](#).

Relative Spectral Power

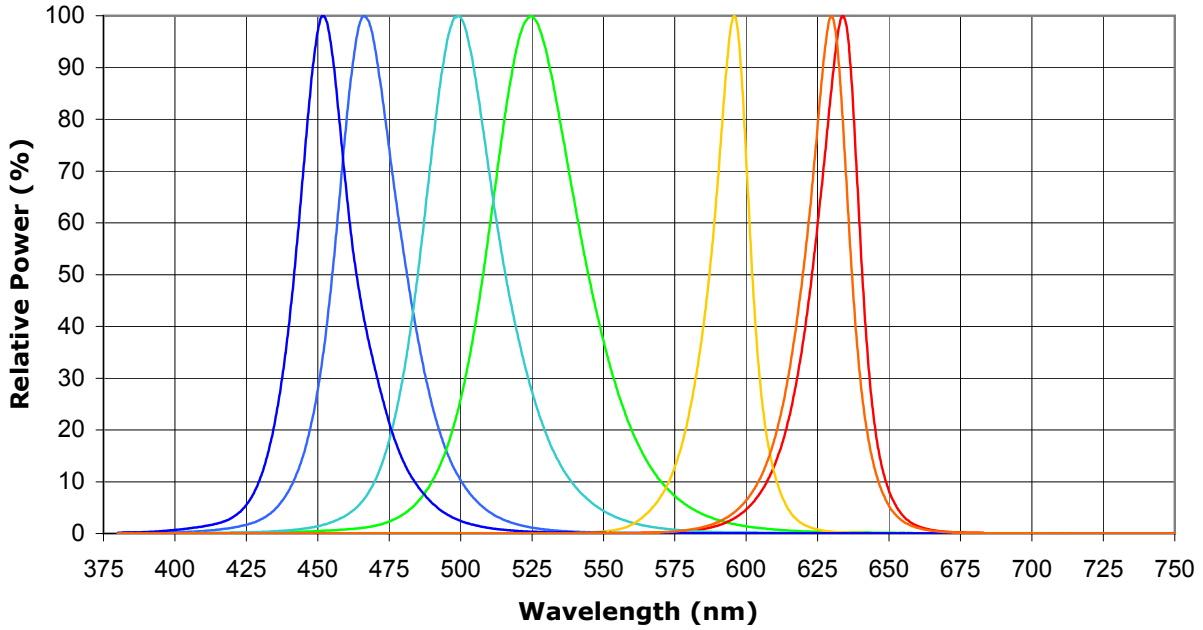

Royal Blue, Blue, Cyan, Green, Amber, Red-Orange, Red

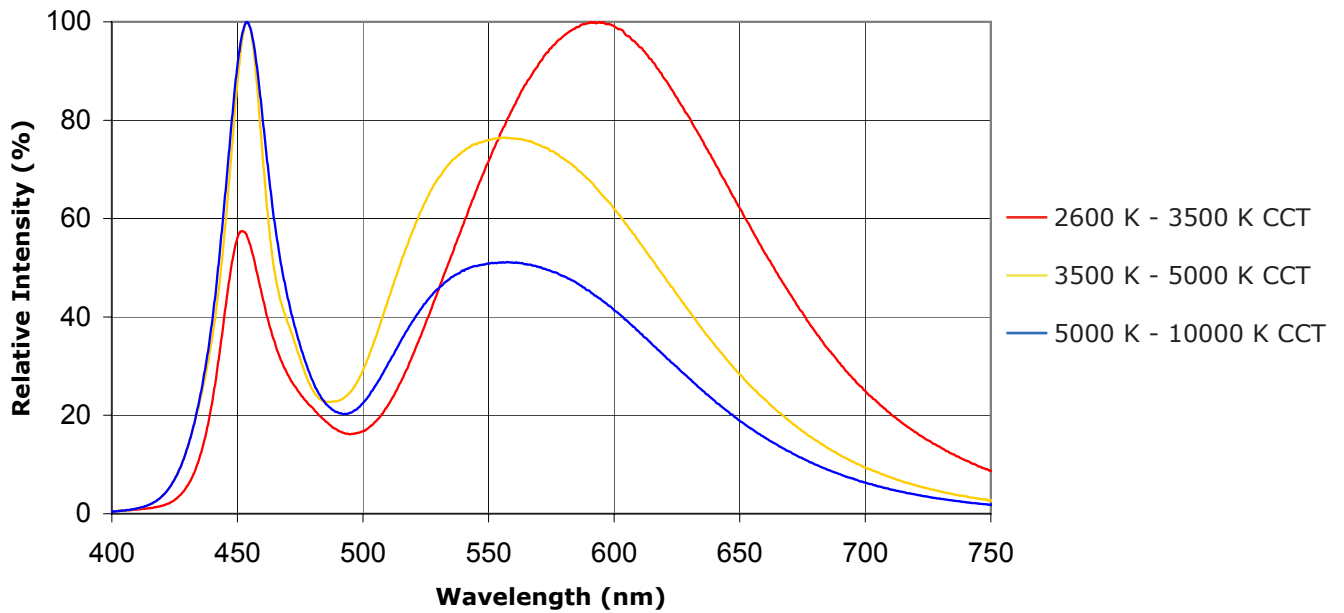

White

Typical Electrical Characteristics ($T_j = 25^\circ\text{C}$)

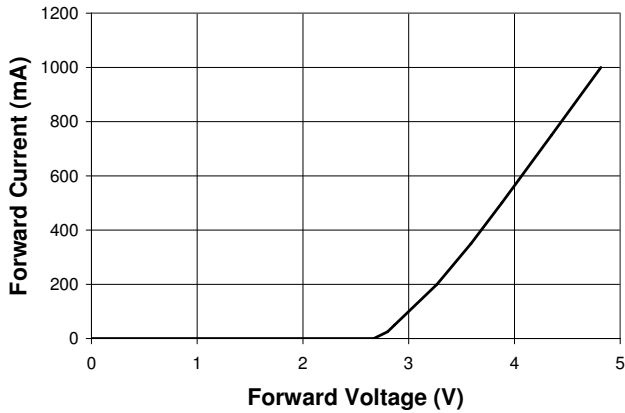

White, Royal Blue, Blue, Cyan, Green

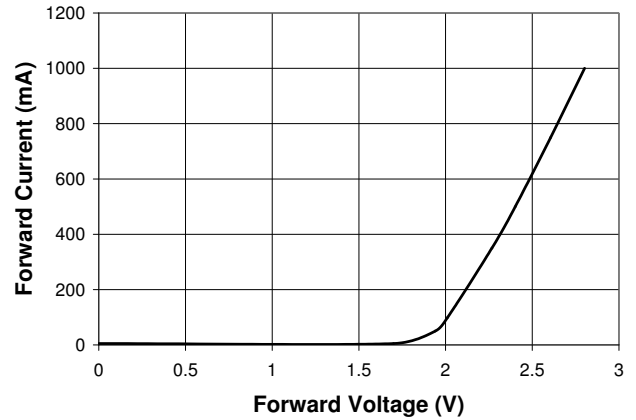

Red, Red-Orange, Amber

Thermal Design

The maximum forward current is determined by the thermal resistance between the LED junction and ambient. Given an existing thermal resistance of $8^\circ\text{C}/\text{W}$ between the junction and the solder point, it is crucial for the end product to be designed in a manner that minimizes the thermal resistance from the solder point to ambient in order to optimize lamp life and optical characteristics.

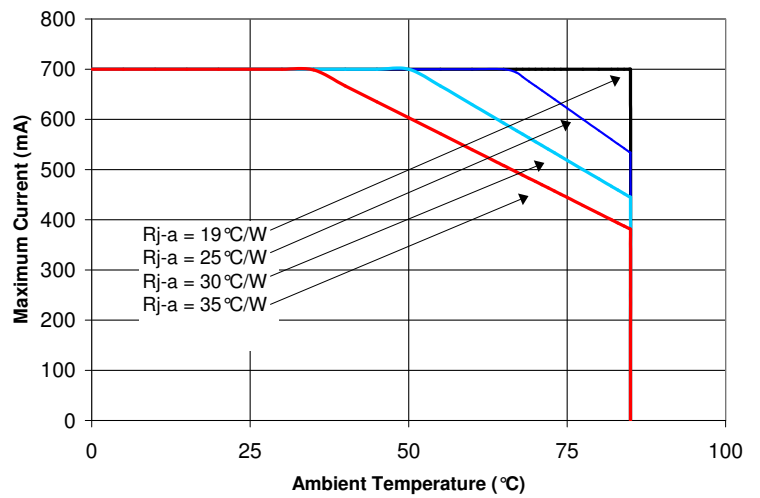

Typical Relative Intensity vs. Current ($T_j = 25^\circ\text{C}$)

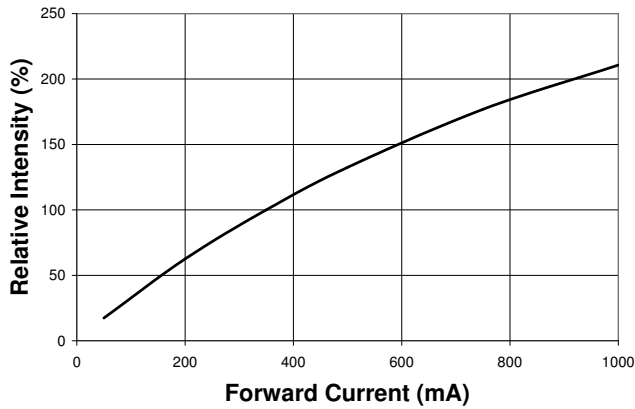

White, Royal Blue, Blue, Cyan, Green

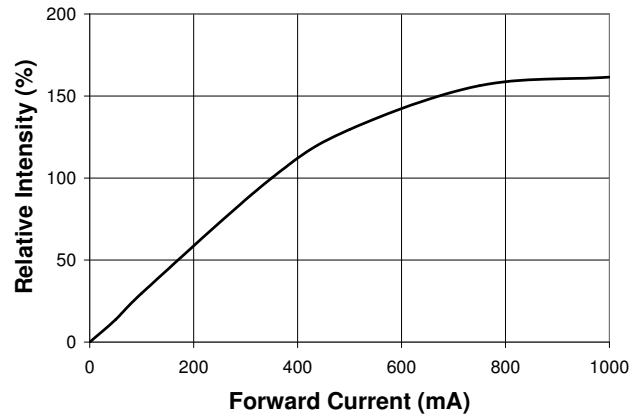

Red, Red-Orange, Amber

Typical Spatial Radiation Pattern

Far Field Pattern

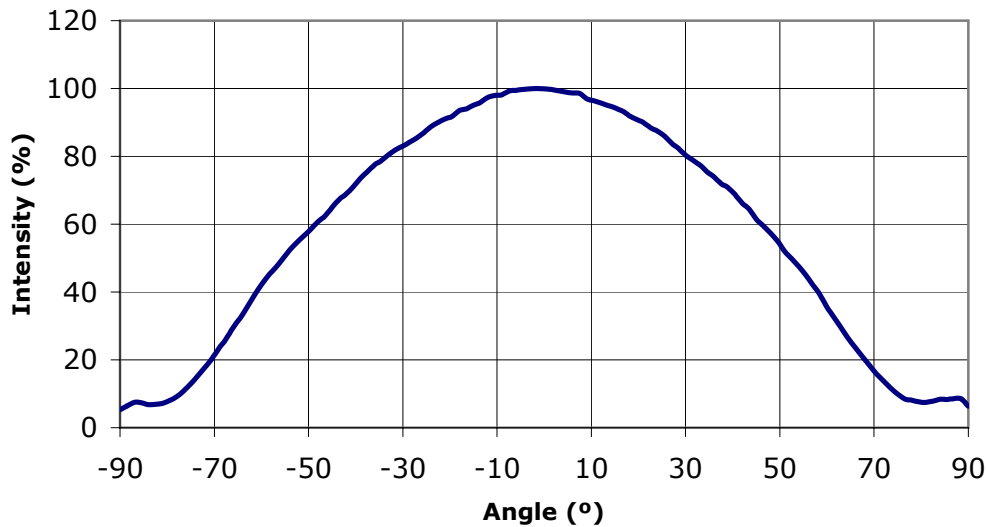

Photometric Output vs. Junction Temperature ($I_f = 350$ mA)

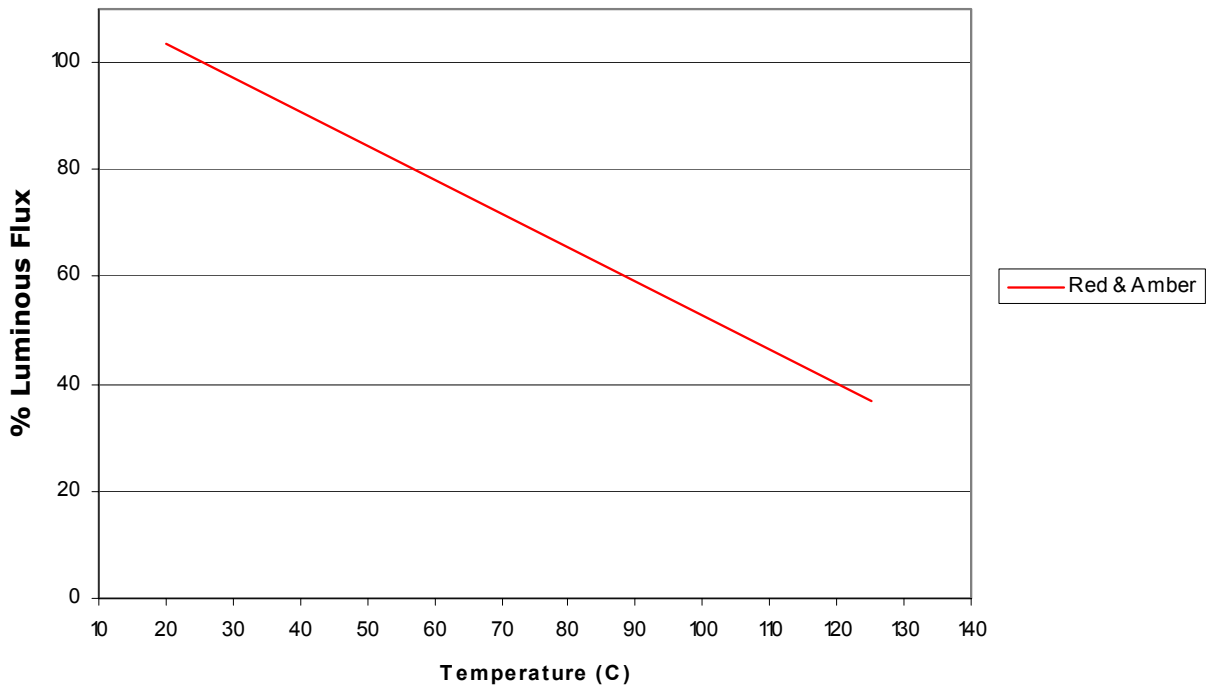
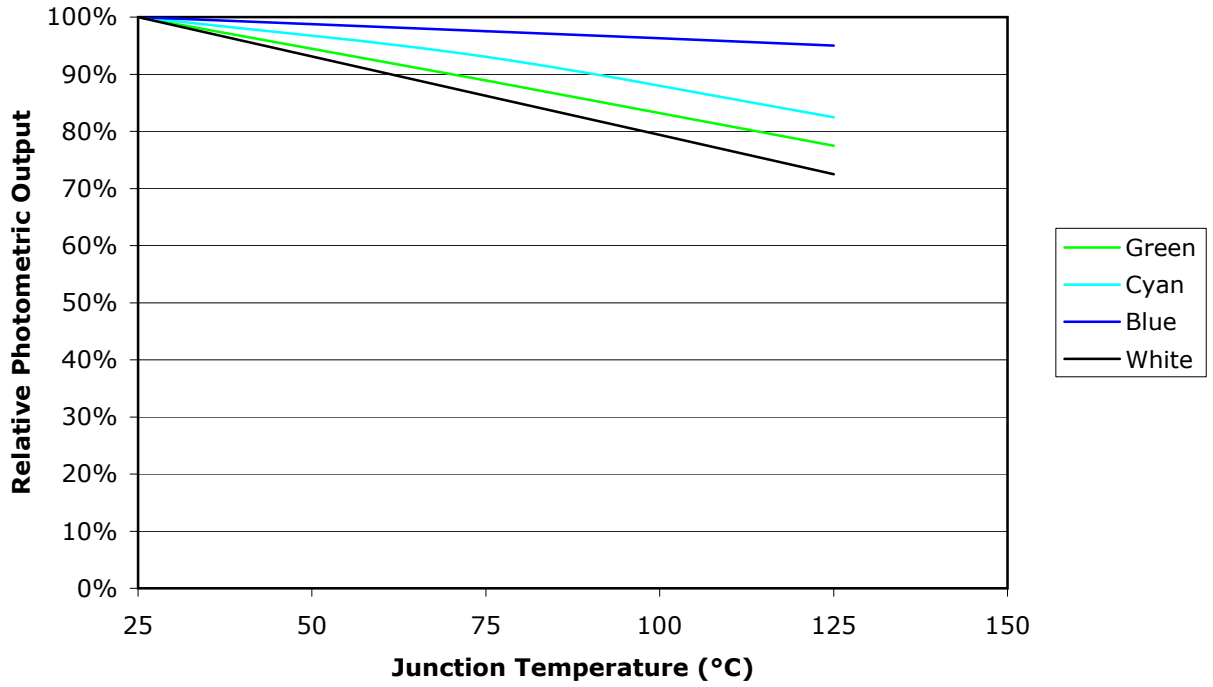

Reflow Soldering Characteristics

The following reflow soldering profiles are provided for reference. Cree recommends that users follow the recommended solder paste profile provided by the manufacturer of the solder paste used. Cree XLamp LEDs are compatible with JEDEC J-STD-020C.

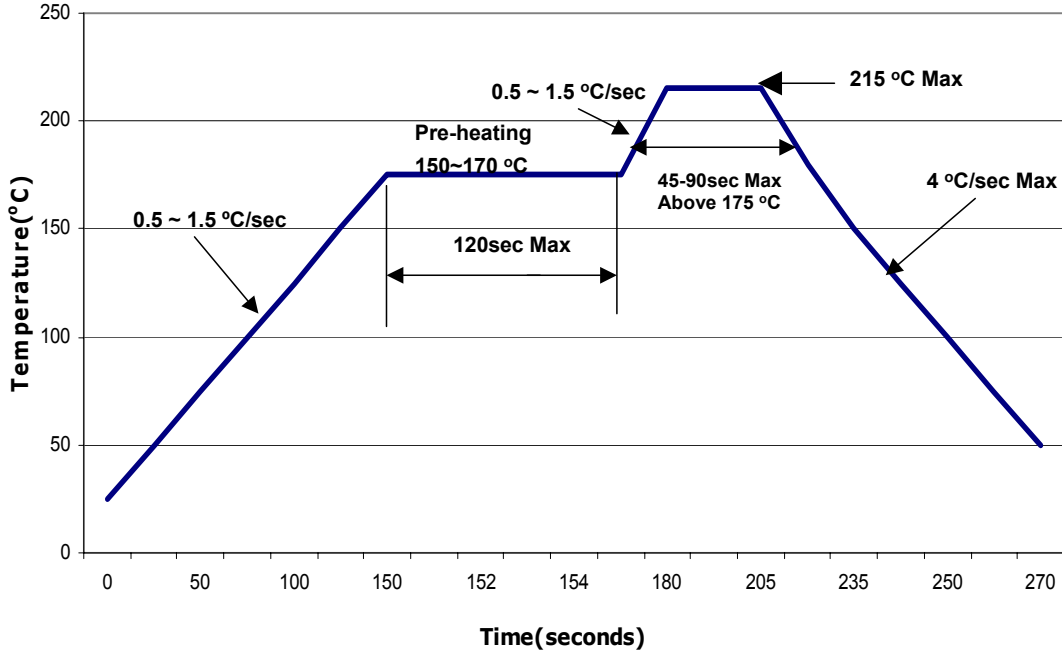

Lead-Based Solder Profile

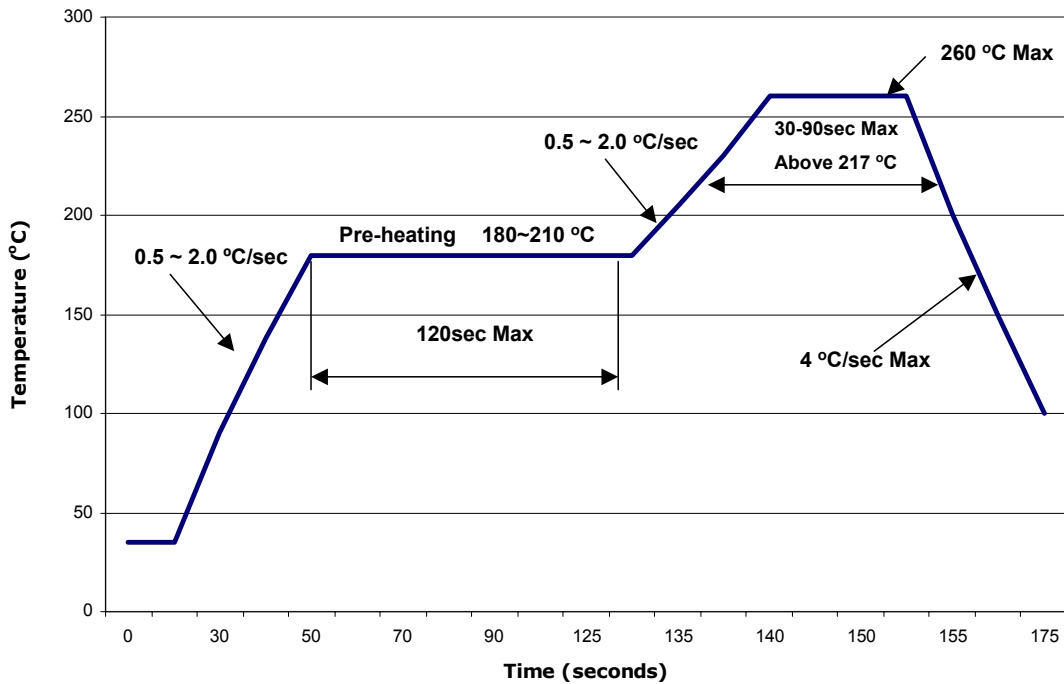

Lead-Free Solder Profile

Notes

Lumen Maintenance Projections

Based on internal long-term reliability testing and standardized forecasting methods, Cree projects XLamp LEDs to maintain an average of 70% lumen maintenance after 50,000 hours, provided the LED junction temperature is maintained at or below 80°C.

Please read the XLamp Reliability application note for more details on Cree’s lumen maintenance testing and forecasting. Please read the XLamp Thermal Management application note for details on how thermal design, ambient temperature, and drive current affect the LED junction temperature.

Moisture Sensitivity

If XLamp LEDs are exposed to excessively moist environments before soldering, damage to the LED may occur during the soldering operation. To avoid this damage, exposed lamps must be baked at 80°C for 24 hours. The following derating table (excerpted from JEDEC J-STD-033 Table 7-1 - Recommended Equivalent Total Floor Life) defines the maximum time (in days) under various humidity and temperature conditions that a lamp may be exposed before requiring baking.

Temperature	Maximum Percent Relative Humidity						
	30%	40%	50%	60%	70%	80%	90%
30°C	9	5	4	3	1	1	1
25°C	12	7	5	4	2	1	1
20°C	17	9	7	6	2	2	1

Within one hour of baking or one hour of opening the original packaging, XLamp LEDs must be stored according to Section 5.3 (Safe Storage) of JEDEC J-STD-033. Otherwise, these parts must be baked again at 80°C for 24 hours and resealed properly within one hour of baking. Do not bake parts at temperatures higher than 80°C, as damage to the reel will occur.

RoHS Compliance

The levels of environmentally sensitive, persistent biologically toxic (PBT), persistent organic pollutants (POP), or otherwise restricted materials in this product are below the maximum concentration values (also referred to as the threshold limits) permitted for such substances, or are used in an exempted application, in accordance with EU Directive 2002/95/EC on the restriction of the use of certain hazardous substances in electrical and electronic equipment (RoHS), as amended through April 21, 2006.

Vision Advisory Claim

Users should be cautioned not to stare at the light of this LED product. The bright light can damage the eye.

Mechanical Dimensions (T_a = 25°C)

All measurements are ±.1mm unless otherwise indicated.

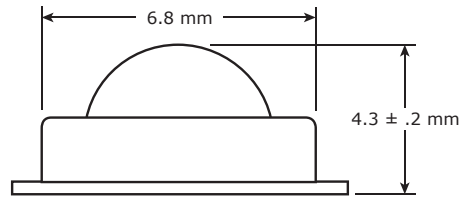
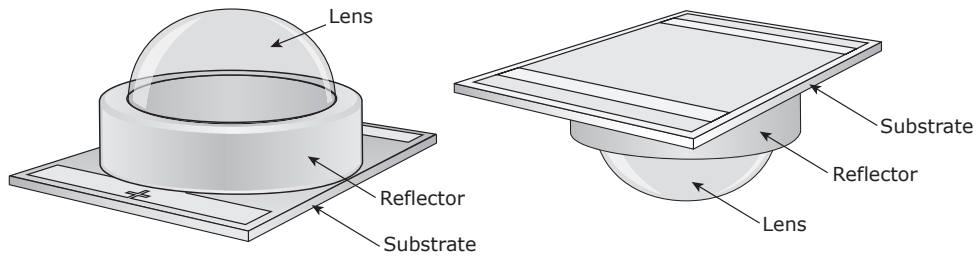

Side View

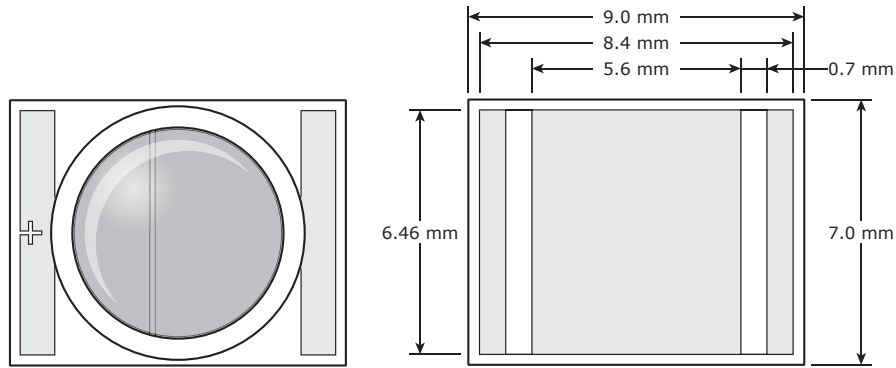

Top View

Bottom View

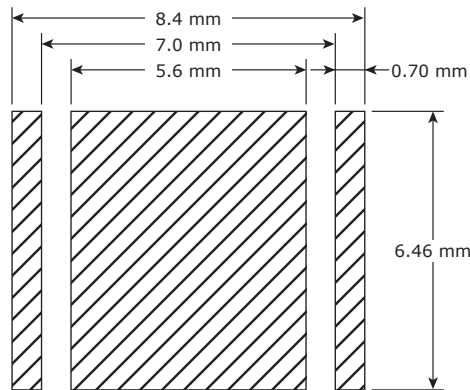

Recommended PC Board Solder Pad

Tape and Reel

All dimensions in mm.

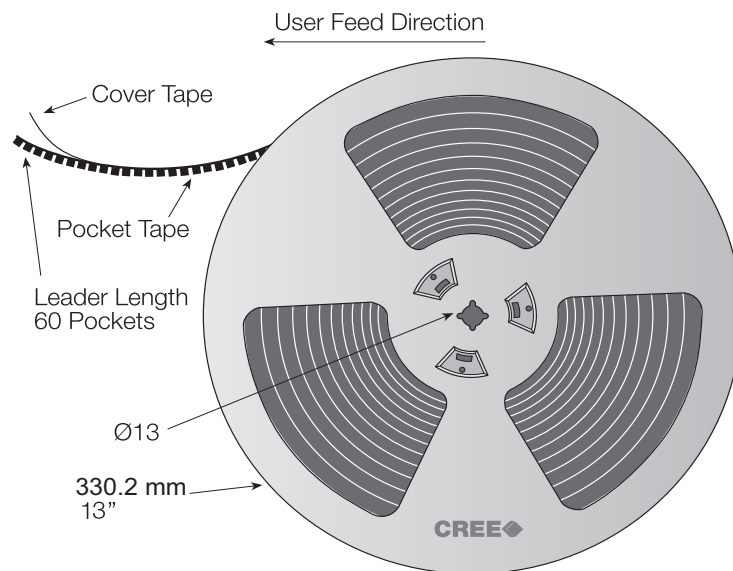
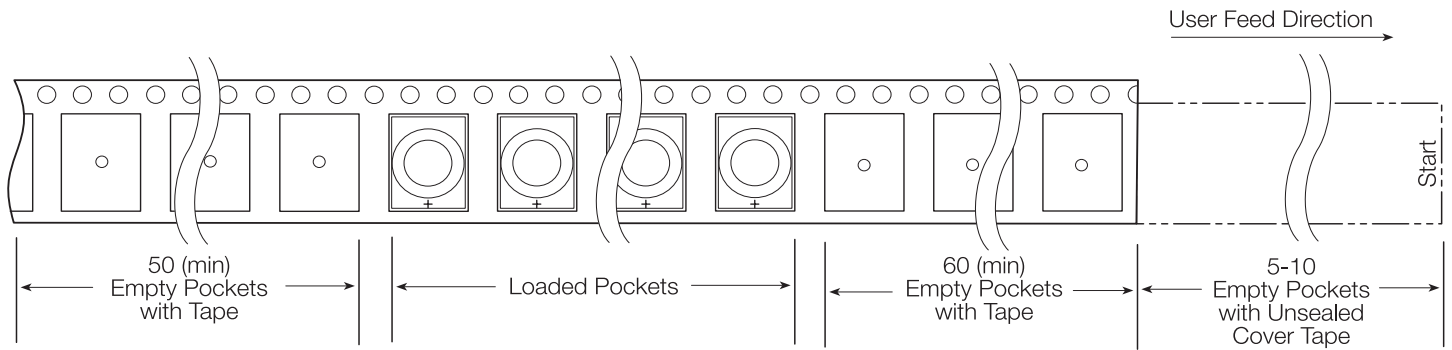
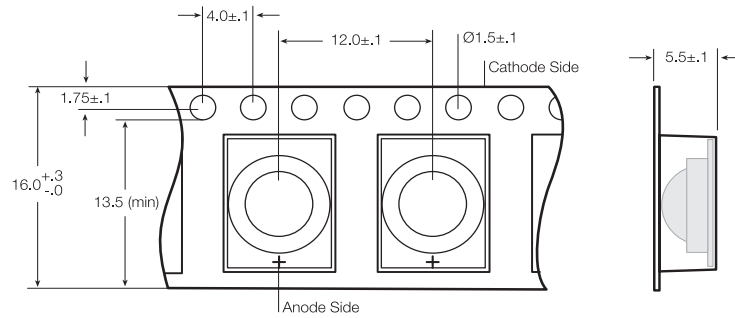
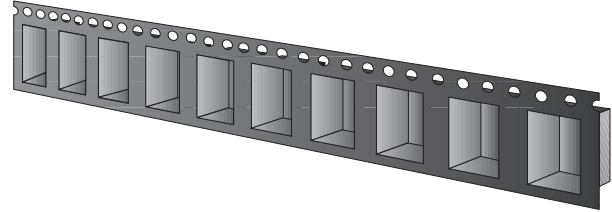
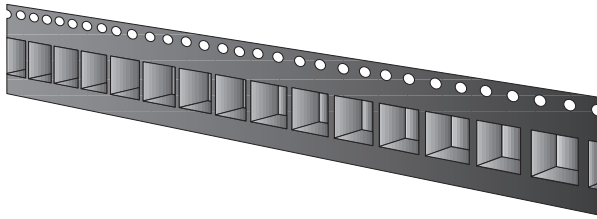

Dry Packaging and Packaging

