



**Type: NSO-01XPE-50130L-19x9.6x4.8**  
**Diameter:  $\Phi 19 \times 9.6 \text{mm}$**   
**Height: 4.8mm**  
**Fov:  $50^\circ \times 130^\circ$**   
**Material: Optical grade Acrylic plastic**  
**Up to 93% efficiency**  
**LED Series: XPE (CREE)**

Applications:  
Streetlight

- Operating Temperature range  $-40^\circ\text{C} \sim +70^\circ\text{C}$  (upper limit  $+80^\circ\text{C}$ )
- Storage Temperature range  $-40^\circ\text{C} \sim +70^\circ\text{C}$  (upper limit  $+80^\circ\text{C}$ )
- Usage and Maintenance :
  1. If necessary, clean lenses with mild soap, water and soft cloth
  2. Never use any commercial cleaning solvents on lenses, like alcohol

### Lens dimensions and Top Views

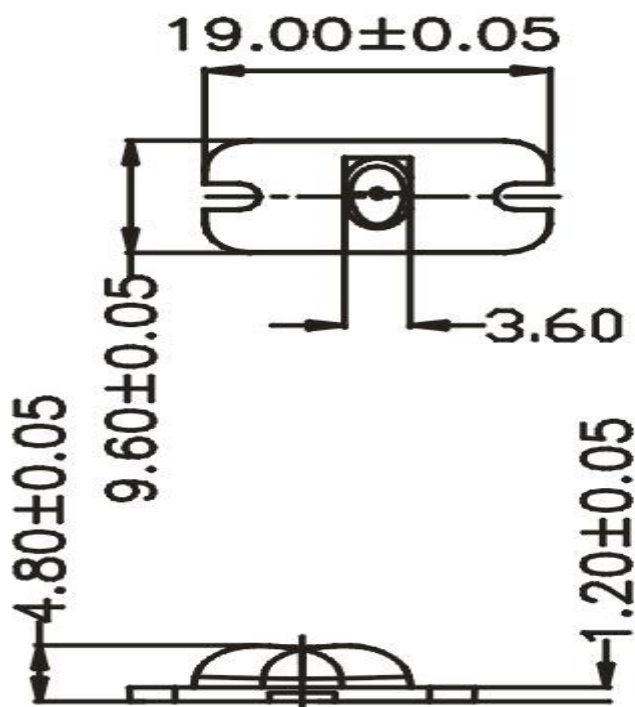

## Beam Pattern

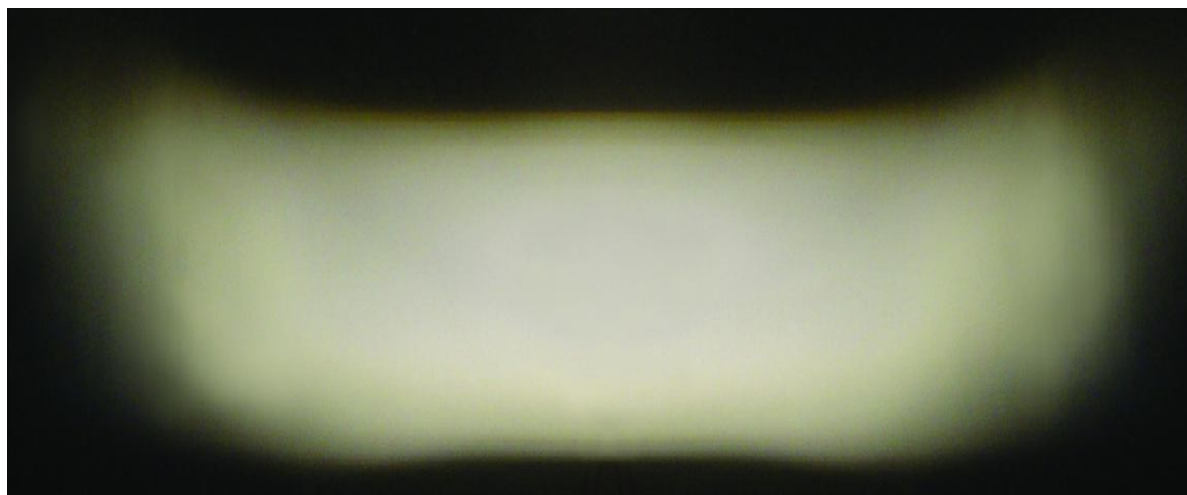

## Light Distribution Curve

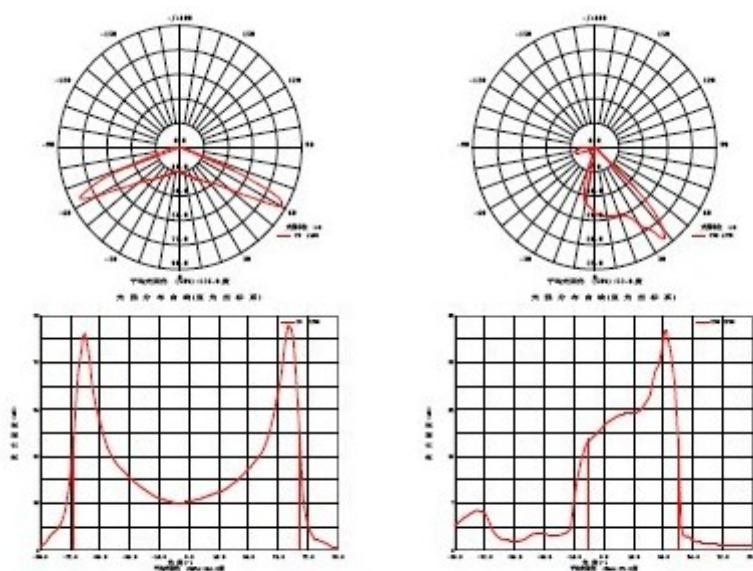

Fig. C0/C180

Fig. C90/C270

C角度范围：0度 - 360度  
C角度间隔：5.0度  
测试速度：快速  
环境温度：25.3℃  
测试人员：BICOM  
测试日期：2010-05-20

γ角度范围：0度 - 180度  
γ角度间隔：1.0度  
测试系统：远方 (EVERFINE)GO-2000E\_V1系统 V1.0.257  
环境湿度：65.0%  
测试距离：6.050米 [K=1.0000]  
备注：整体式灯具，灯具效率(相对)计为100%。