

LL01NI-DZ2040L-Mx Data Sheet

For Nichia Multi-Color and Single-Color LEDs



Features:

- High efficiency
- Available in 1 beam Patterns
- Optimized for uniform effects
- Lens with Housing

Typical applications :

- Stage Lighting
- Street Lights
- Decorative Light
- Architectural Lighting
- Down Light

Table of Contents

General Information.....	2
General Specifications.....	2
Optical Specifications.....	3
Mechanical Specifications.....	4
Illumination charts.....	5
Package Specifications.....	6
Product Nomenclature.....	7

General Information

- **Compatible Led Type :**

The LL01NI-DZ2040L-Mx single lens are optimized for both Multi-Color R.G.B Nichia LEDs and Single-Color Nichia LEDs (Nichia 083A White)from Nichia Opto. ⁽¹⁾

- **Beam Angle Type :**

An optimized profile integrate different front shape enable the generation of one lens model : oval beam (20*40deg). ⁽²⁾

- **The Way to Assembly :**

The Lens should be assembled to the PCB board or MCPCB upon LEDs which provides the most appropriate related position, so as to achieve the best uniform results

*** Manually installation or if necessary thermal glue are recommended.**

- **Function :**

LL01NI-DZ2040L-Mxprovides exceptional color mixing result with the highest efficiency through careful engineering and precision manufacturing process.

General Specifications

- Lens Material Optical Grade PMMA PC
- Operating Temperature range -40°C ~ + 70°C (upper limit +80°C)
- Storage Temperature range -40°C ~ + 70°C (upper limit +80°C)

*Average transmittance in visible spectrum 400nm~700nm > 90%

Notes:

(1) Nichia 083A is a trademark of Nichia,Inc , for technical information on LEDs, please refer to Nichia,Inc, <http://www.nichia.com>

(2) Typical beam divergence will be affected by different color of LEDs.

Optical Specifications [Typical beam Angle and intensity (cd/lm) of LL01 lens]

- Nichia 083A LED

Typical Cone Angle (degree) ⁽³⁾ with Nichia 083A			
Part Number	Red LEDs	Green LEDs	Blue LEDs
LL01NI-DZ2040L-M2	--	--	--

The typical cone angle measures where the luminous intensity is 90% of the peak value of intensity. This typical cone varies with LED color due to different chip size and chip position tolerance.

Typical on axis intensity (cd/lm) ⁽⁴⁾ with Nichia 083A			
Part Number	Red LEDs	Green LEDs	Blue LEDs
LL01NI-DZ2040L-M2	--	--	--

Luminous intensity depends on the flux binning and tolerance of the LEDs. Please refer to the LEDs data sheet for more details on Flux binning and mechanical tolerance.

- Nichia 083A LED

Typical Cone Angle (degree) ⁽³⁾ with Nichia 083A			
Part Number	White LEDs	Warm white LEDs	
LL01NI-DZ2040L-M2	23*74	--	

The typical cone angle the full angle measured where the luminous intensity is 90% of the peak value of intensity. That typical cone varies with LED color due to different chip size and chip position tolerance.

Typical on axis intensity (cd/lm) ⁽⁴⁾ with Nichia 083A			
Part Number	White LEDs	Warm white LEDs	
LL01NI-DZ2040L-M2	290	--	

Luminous intensity depends on the flux binning and tolerance of the LEDs. Please refer to the LEDs data sheet for more detail on Flux binning and mechanical tolerance

Notes:

(3) The typical divergence will be changed by different color, chip size and chip position tolerance. The typical total divergence is the full angle measured where the luminous intensity is half of the peak value.

(4) The efficiency value listed above is the total value of the whole lens model, the value depends on the total flux of the LED used. Luminous intensity depends on the LEDs flux and its tolerances, for more details of LED flux, please check Nichia data sheet at <http://www.nichia.com>

Mechanical Specifications

• Usage and Maintenance :

1. If necessary, clean lenses with mild soap, water and soft cloth
2. Never use any commercial cleaning solvents on lenses, like alcohol
3. Please handle or install lenses with wearing gloves, skin oils may damage lens or its optical characteristic.

1. Lens + Leds+MCPCB assembly instruction

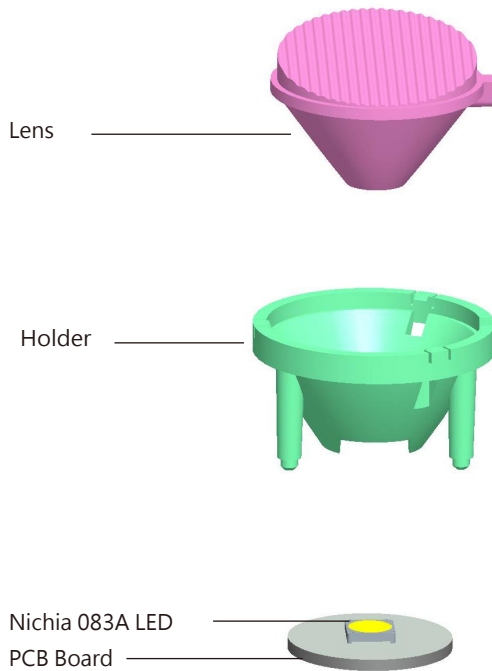

2. View assembly lens with MCPCB:

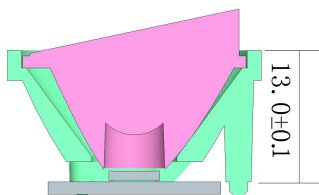

3. Lens dimensions and Top Views:

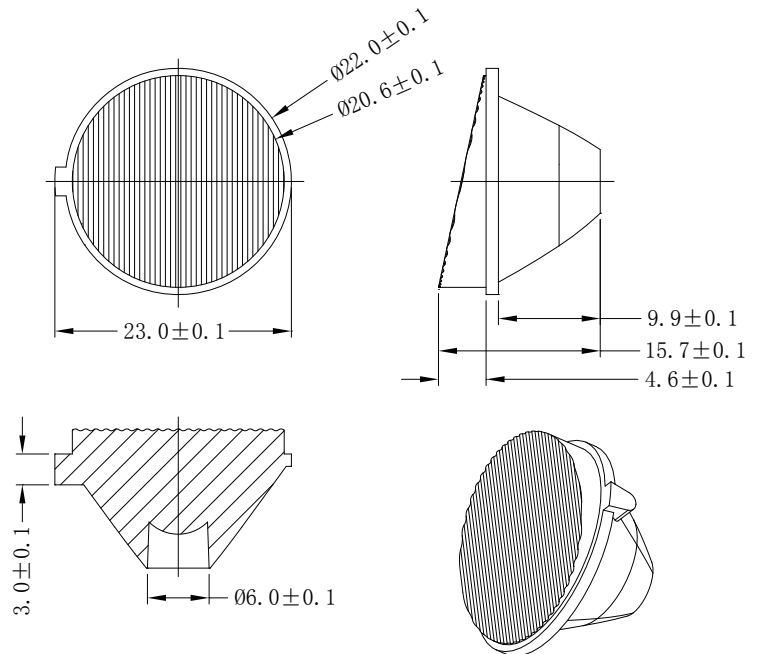

4. Lens assembly Dimensions and Top Views :

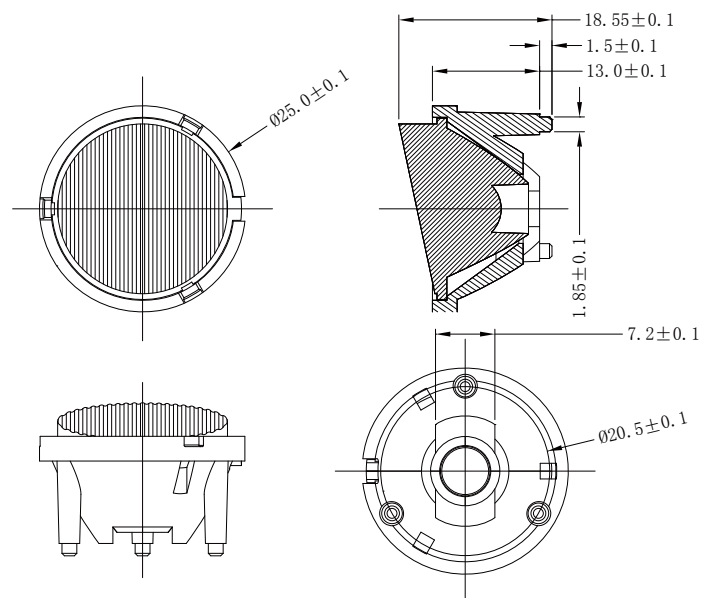

- Notes:
- (1) All dimensions are in mm.
 - (2) Drawing not to scale.
 - (3) Collimator material is PMMA.

Illumination charts

*Nichia single white LED: Nichia 083A

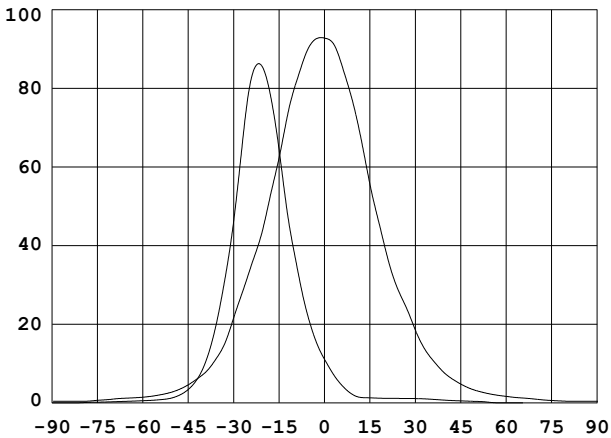
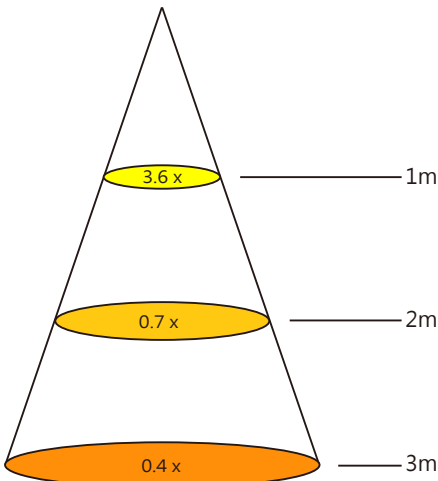
LL01NI-DZ2040L-M2	
1. Beam Pattern	
	
2. Light Distribution Curve	
	
3. Illuminance	
	

Notes: The Flux of Nichia 083A LED is 81 lm

Package

Item	Quantity	Total	Size (long*width* high)
Tray	81	81pcs	34*30*3.5 cm
Inner box	10tray/box	810pcs	35*31*21 cm
Outer box	2 Inner box/outer box	1620pcs	64.7*36.5*24 cm

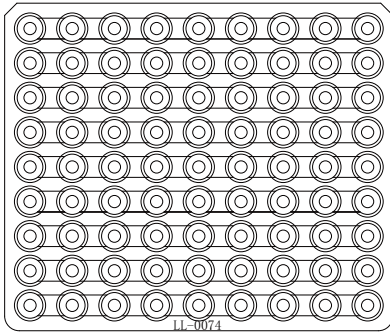

81pcs/tray

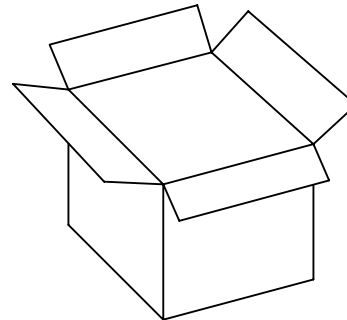
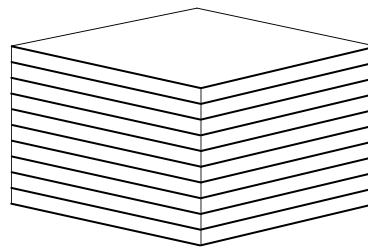

810pcs/inner box

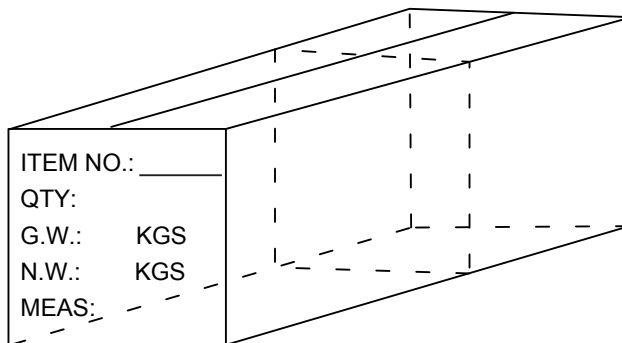

1620pcs/outer box

Product Nomenclature

