



深圳市绿色半导体照明有限公司
Light Green International Co.,Ltd.

SPECIFICATIONS FOR LIGHT GREEN SURFACE MOUNT LED

Model: **LGIXFMF 75AA-ET2**

Company Name: _____

Confirmed By
Customer: _____

DATE: _____

深圳市绿色半导体照明有限公司

SHENZHEN Light Green International CO., LTD

深圳市南山区松白路百旺信工业园二区第 6 栋

6th wing, 2nd Block of BaiWangXing Industry Park,

Songbai Road,Nanshan District ShenZhen,China,P.C:518108

TEL: (86+755)29529100

FAX: (86+755)29529200

[Http://www.light-green.cn](http://www.light-green.cn)

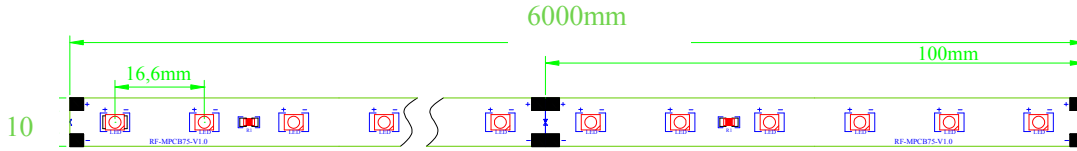

Technical Features

Size of the strip (L x W x H)

6000mm x10mm x4mm

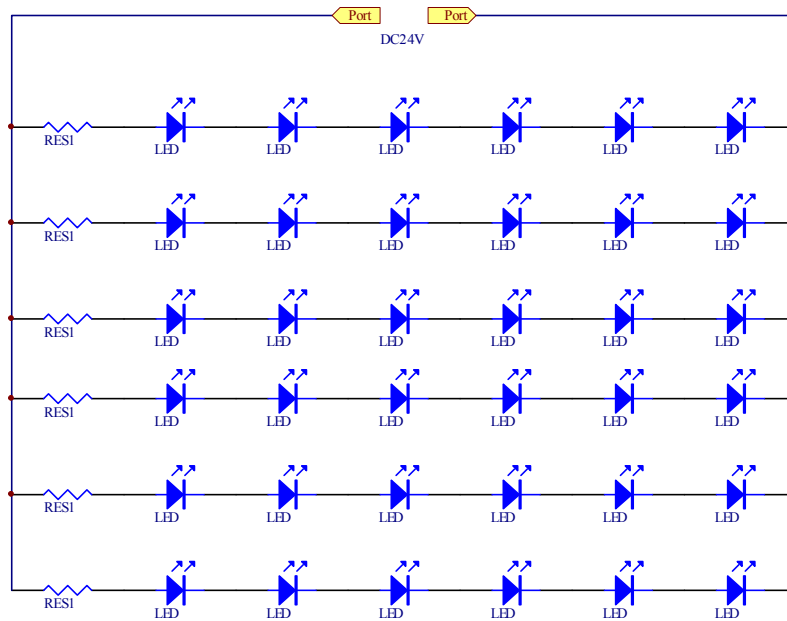

Technical Operating Data

Product	Color	Number of LEDS/M	Voltage [V DC]	Power [W]	Current [MA]	Viewing angle[°]	Wave length[nm] Color temp[°]	Lum.[lm] IV[mcd]
LGI-WFMF75AA-ET2	White	60	12	4.8	400	120	6500K	340lm
LGI-IFMF75AA -ET2	Warm white	60	12	4.8	400	120	3200K	217lm
LGI-BFMF75AA- ET2	Blue	60	12	4.8	400	120	465nm	51lm
LGI-GFMF75AA - ET2	Green	60	12	4.8	400	120	565nm	110lm
LGI-YFMF75AA - ET2	Yellow	60	12	4.8	400	120	588nm	51lm
LGI-OFMF75AA - ET2	Orange	60	12	4.8	400	120	625nm	54lm

All Data are related to one meter

Due to the special conditions of the manufacturing processes of LED the typical data of technical parameters can only reflect statistical figures and do not necessarily correspond to the actual parameters of each single product which could differ from the typical data.



Feature

- ◆ Viewing angle: 120 deg
- ◆ The materials of the LED dice is InGaN
- ◆ 3.50mm×2.80mm×1.90mm SMT-LED
- ◆ RoHS compliant lead-free soldering compatible

Package Outline

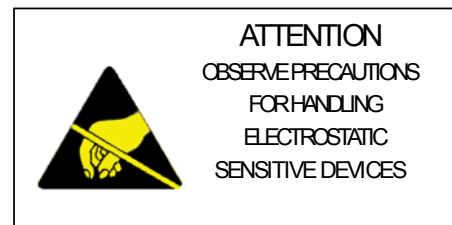
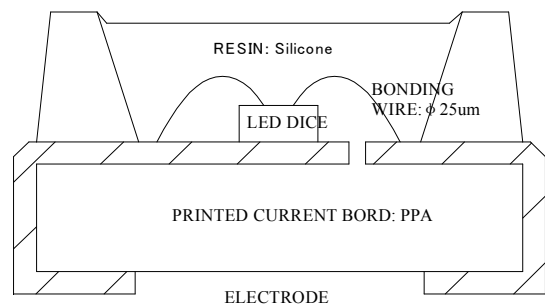
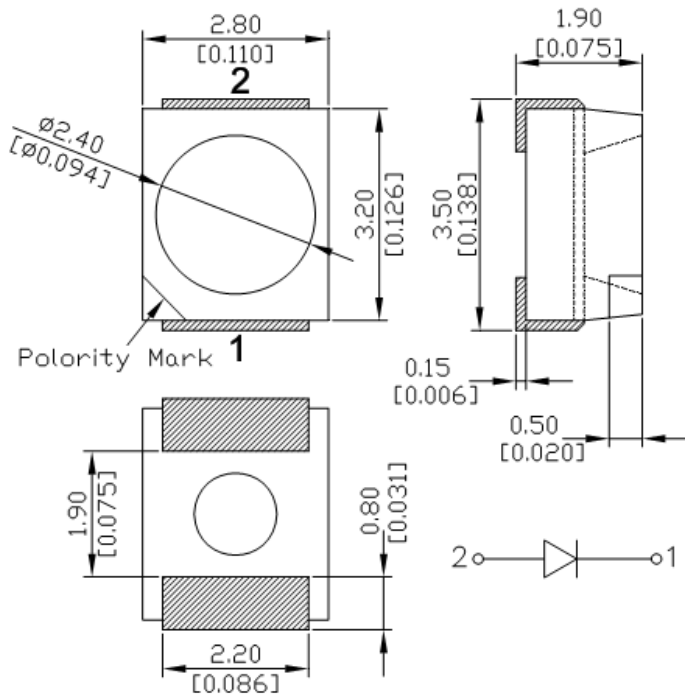

NOTES:

1. All dimensions are in millimeters (inches);
2. Tolerances are $\pm 0.2\text{mm}$ (0.008inch) unless otherwise noted.



Reflow profile

■ Soldering condition

- Recommended soldering conditions

Reflow Soldering		Hand Soldering	
Pre-heat	160~180°C	Temperature	300°C Max.
Pre-heat time	120 seconds Max.	Soldering time	3 second Max. (one time only)
Peak temperature	260°C Max.		
Soldering time	10 seconds Max.		
Condition	Refer to Temperature-profile		

- After reflow soldering rapid cooling should be avoided

■ Temperature-profile (Surface of circuit board)

Use the following conditions shown in the figure.

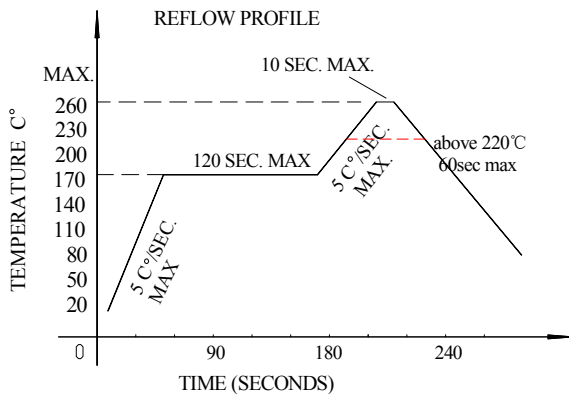

1. Reflow soldering should not be done more than two times
2. When soldering ,do not put stress on the LEDs during heating

■ Soldering iron

1. When hand soldering, keep the temperature of the iron under 300°C, and at that temperature keep the time under 3 sec.
2. The hand soldering should be done only a time
3. The basic spec is ≤5 sec. when the temperature of 260°C, do not contact the resin when hand soldering

■ Rework

1. Customer must finish rework within 5 sec und
2. The head of iron can not touch the resin
3. Twin-head type is preferred.

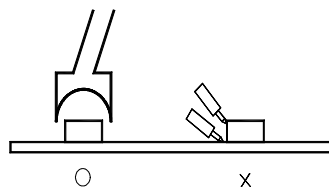

■ CAUTIONS

The encapsulated material of the LEDs is silicone . Therefore the LEDs have a soft surface on the top of package. The pressure to the top surface will be influence to the reliability of the LEDs. Precautions should be taken to avoid the strong pressure on the encapsulated part. So when using the picking up nozzle, the pressure on the silicone resin should be proper



Reliability

(1) TEST ITEMS AND RESULTS

Type	Test Item	Test Conditions	Note	Number of Damaged
Environmental Sequence	Resistance to Soldering Heat(Reflow Soldering)	Tsld=260℃, 10sec	2 times	0/22
	Temperature Cycle	-40℃ 30min ↑↓5min 80℃ 30min	100 cycle	0/100
	Thermal Shock	-40℃ 15min 80℃ 15min	100 cycle	0/100
	High Temperature Storage	T _a =80℃	1000 hrs	0/100
	Temperature Humidity Storage	T _a =60℃ RH=90%	1000 hrs	0/100
	Low Temperature Storage	T _a =-30℃	1000 hrs	0/100
	Power On/off Cycle Test IF=20mA	On 2 hours Off 10min	100 cycle	0/100
Operation Sequence	Life Test	T _a =25℃ I _F =20mA	1000 hrs	0/100
	High Humidity Heat Life Test	60℃ RH=90% I _F =20mA	500 hrs	0/100
	Low Temperature Life Test	T _a =-20℃ I _F =20mA	1000 hrs	0/100
	Drop	75cm	3 times	0/10

(2) CRITERIA FOR JUDGING THE DAMAGE

Item	Symbol	Test Conditions	Criteria for Judgement	
			Min.	Max.
Forward Voltage	VF	IF=10mA	—	U.S.L*)×1.1
Reverse Current	IR	VR=5V	—	U.S.L*)×2.0
Luminous Intensity	IV	IF=10mA.	L.S.L**)×0.7	—

U.S.L.: Upper Standard Level

L.S.L.: Lower Standard Level



Package:

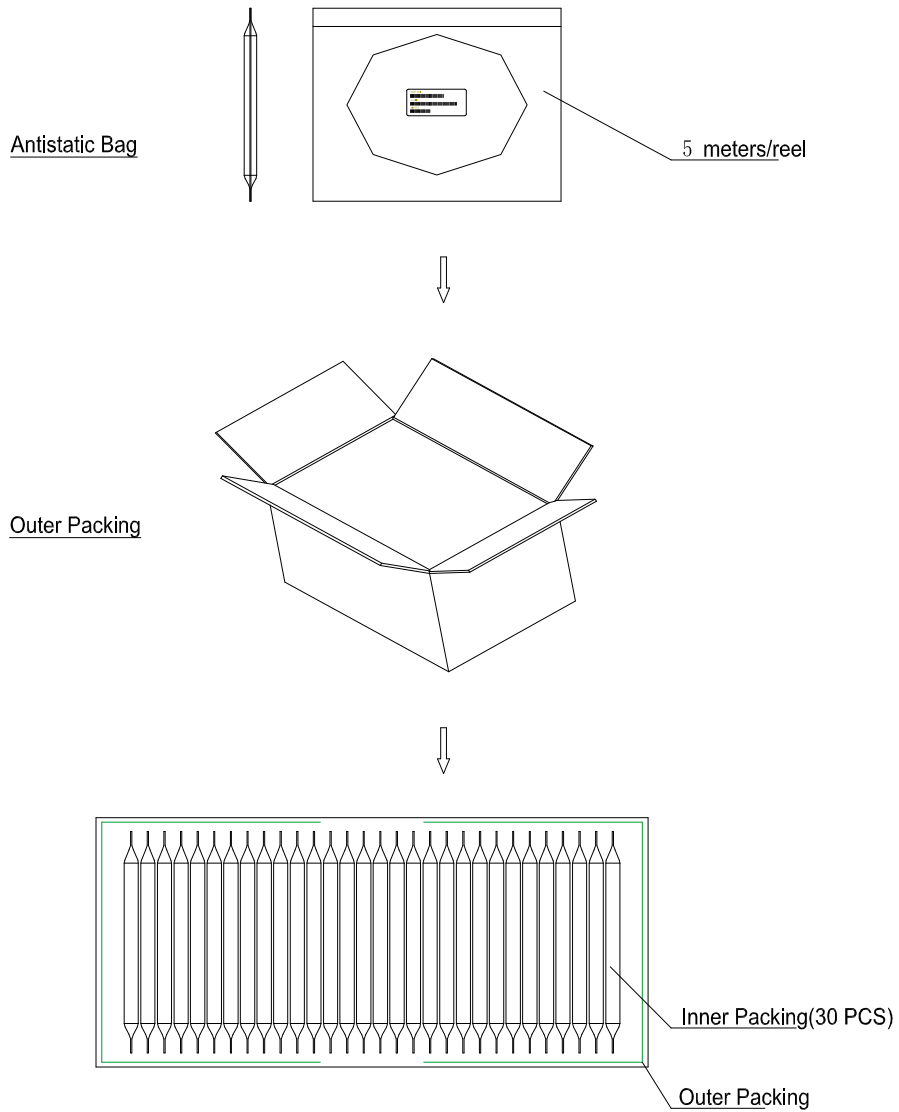

APPROVED BY:		CHECKED BY:		PREPARED BY:	
DATE:		DATE:		DATE:	