

SPECIFICATION

HPL- H77X X 1 C0

3W LED

Lens & Assembly Type :

N : No special Work
S : with Star
A : Lens 25°
B : Lens 45°
L : Lens 120°
P : Lens 100°/50°
G : Star & Lens 25°
H : Star & Lens 45°
F : Star & Lens 120°
U : Star & Lens 100°/50°

Color :

R : Red
G : Green
B : Blue
D : Royal Blue
A : Amber
O : Orange

Caution:

Depends on different chips structures, the thermal pad could has a polarity as Anode. To avoid the risk of circuit-fail, **It is strongly recommended to suppose the condition (Anode – thermal pad)** while designing a circuit.

Part Number Matrix

Without Star:

Colors / Type	Flat Type	Lens 25°	Lens 45°	Lens 120°	Lens 100°/50°
Green	HPL-H77NG1C0	HPL-H77AG1C0	HPL-H77BG1C0	HPL-H77LG1C0	HPL-H77PG1C0
Blue	HPL-H77NB1C0	HPL-H77AB1C0	HPL-H77BB1C0	HPL-H77LB1C0	HPL-H77PB1C0
Royal Blue	HPL-H77ND1C0	HPL-H77AD1C0	HPL-H77BD1C0	HPL-H77LD1C0	HPL-H77PD1C0
Red	HPL-H77NR1C0	HPL-H77AR1C0	HPL-H77BR1C0	HPL-H77LR1C0	HPL-H77PR1C0
Amber	HPL-H77NA1C0	HPL-H77AA1C0	HPL-H77BA1C0	HPL-H77LA1C0	HPL-H77PA1C0
Orange	HPL-H77NO1C0	HPL-H77AO1C0	HPL-H77BO1C0	HPL-H77LO1C0	HPL-H77PO1C0

With Star:

Colors / Type	Star & Flat Type	Star & Lens 25°	Star & Lens 45°	Star & Lens 120°	Star & Lens 100°/50°
Green	HPL-H77SG1C0	HPL-H77GG1C0	HPL-H77HG1C0	HPL-H77FG1C0	HPL-H77UG1C0
Blue	HPL-H77SB1C0	HPL-H77GB1C0	HPL-H77HB1C0	HPL-H77FB1C0	HPL-H77UB1C0
Royal Blue	HPL-H77SD1C0	HPL-H77GD1C0	HPL-H77HD1C0	HPL-H77FD1C0	HPL-H77UD1C0
Red	HPL-H77SR1C0	HPL-H77GR1C0	HPL-H77HR1C0	HPL-H77FR1C0	HPL-H77UR1C0
Amber	HPL-H77SA1C0	HPL-H77GA1C0	HPL-H77HA1C0	HPL-H77FA1C0	HPL-H77UA1C0
Orange	HPL-H77SO1C0	HPL-H77GO1C0	HPL-H77HO1C0	HPL-H77FO1C0	HPL-H77UO1C0

1. Features

- Dimension : 7.0mm(L)×7.0mm(W)
- 3W High Flux type
- All Metal Design Cu PCB/AI reflector
- Low thermal resistance
- The InGaN or AlInGaP Chip inside

2. Applications

- Traffic signaling
- Interior & exterior automotive lighting
- Decorative and landscape lighting
- Signage and channel letter
- Portable light source
- Decorating and entertainment lighting
- Architectural lighting



3. Absolute Maximum Ratings

(T_j=25°C)

Parameter		Symbol	Rating	Unit
Power Dissipation	Red	P	1.75	W
	Green		2.66	
	Blue		2.66	
	Amber		1.75	
	Orange		1.75	
	Royal Blue		2.66	
Forward Current		IF	700	mA
Forward Pulse Current (1/10 Duty Cycle, 400msec Pulse Width)		IFP	1000	mA
Thermal Resistance, Junction-Case		Rth, J-C1	10	°C/W
Reverse Voltage		VR	5	V
LED Junction Temperature		Tj	125	°C
Operating Temperature Range		Topr	-40°C to + 80°C	
Storage Temperature Range		Tstg	-40°C to + 120°C	
Soldering Condition		Tsol	260°C For 5 Seconds	

Note: 1. The thermal resistance value is measured with MCPCB (Star).

4. Initial Electrical/Optical Characteristics

• Forward Voltage

(T_j=25°C)

Color	Forward Voltage					
	Symbol	MIN.	TYP.	MAX.	Test Condition	Unit
Red→R	V _F	1.83	2.5	3.03	I _F = 700mA	V
Green→G		3.03	3.8	4.23		
Blue→B		3.03	3.8	4.23		
Amber→A		1.83	2.5	3.03		
Orange→O		1.83	2.5	3.03		
Royal Blue→D		3.03	3.8	4.23		

● **Reverse Current** (Tj=25°C)

Color	Reverse Current					
	Symbol	MIN.	TYP.	MAX.	Test Condition	Unit
ALL COLORS	I_R	-	-	100	$V_R = 5V$	μA

● **Luminous Flux** (Tj=25°C)

Color	Luminous Flux (With Lens type / Flat type)					
	Symbol	MIN.	TYP.	MAX.	Test Condition	Unit
Red→R	Φ_V	-	72/52	75/58	IF = 700mA	lm
Green→G		-	110/69	117/75		
Blue→B		-	28/19	30/21		
Amber→A		-	70/57	84/63		
Orange→O		-	94/66	99/70		

● **Radiometric Flux**

(Tj=25°C)

Color	Radiometric Flux (With Lens type / Flat type)					
	Symbol	MIN.	TYP.	MAX.	Test Condition	Unit
Royal Blue→D	Φ_e	-	340/300	-	$I_F = 700mA$	mW

● **Dominate wavelength & Peak wavelength** (Tj=25°C)

Color	Color Temperature & Dominate Wavelength					
	Symbol	MIN.	TYP.	MAX.	Test Condition	Unit
Red→R	λ_d	620	-	640	IF = 700mA	nm
Green→G		520	-	550		
Blue→B		460	-	490		
Amber→A		584.5	-	597		
Orange→O		610	-	620		
Royal Blue→D	λ_p	440	-	460		

• **View Angle** (T_j=25°C)

Color	Viewing Angle							Test Condition	Unit
	Symbol	Flat type	120° Lens	25° Lens	45° Lens	100°/50° Lens			
R,A,O,G,B,D	2θ _{1/2}	110°	120°	25°	45°	100°/50°	I _F = 700mA	Deg.	

• **Spectra half-width** (T_j=25°C)

Color	Spectra half-width					Test Condition	Unit
	Symbol	MIN.	TYP.	MAX.			
Red→R	Δλ	-	20	-	I _F = 700mA	nm	
Green→G		-	30	-			
Blue→B		-	30	-			
Amber→A		-	15	-			
Orange→O		-	18	-			
Royal Blue→D		-	30	-			

• Typical Radiation Pattern

(@ $I_F=700\text{mA}$, $T_j=25^\circ\text{C}$)

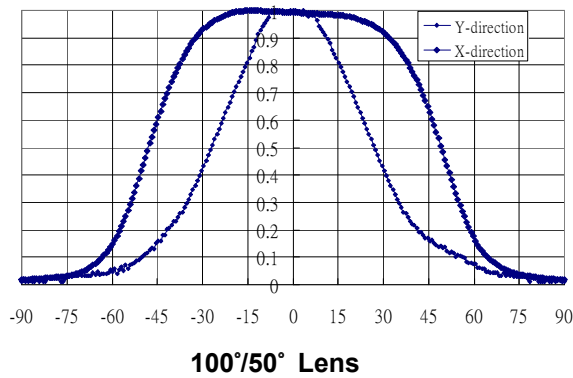
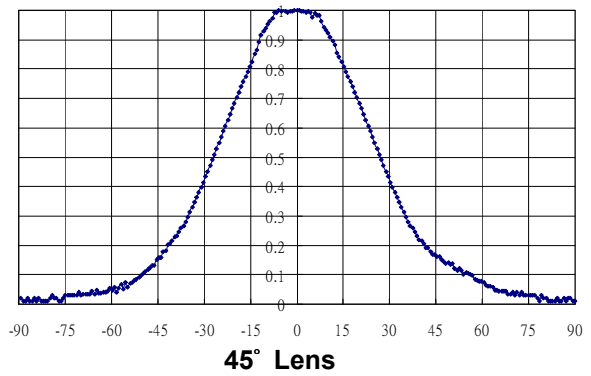
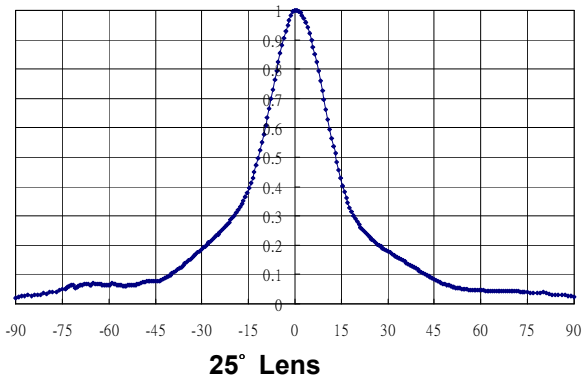
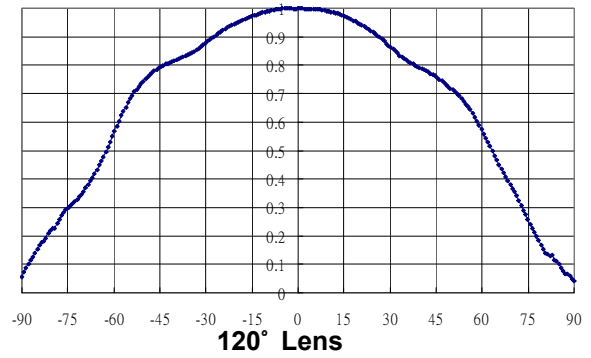
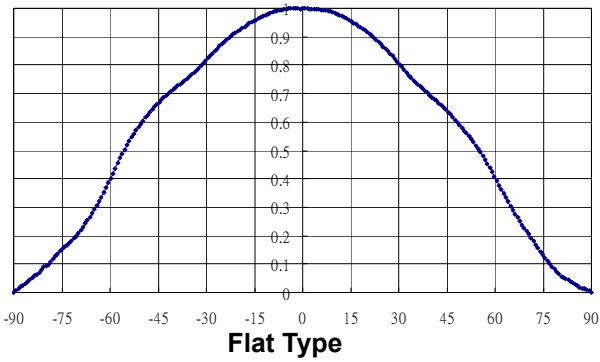

• **Bin Code List for Reference**

(T_j=25°C)

Forward Voltage Bins

(@ I_F=700mA, T_j=25°C)

Item	Bin Code	Symbol	Condition	Min.	Max.	Unit
Forward Voltage Color: R,A,O	C	V _F	I _F = 700 [mA]	1.83	2.07	V
	D			2.07	2.31	
	E			2.31	2.55	
	F			2.55	2.79	
	G			2.79	3.03	
Forward Voltage Color: G,B,D	H			3.03	3.27	
	J			3.27	3.51	
	K			3.51	3.75	
	L			3.75	3.99	
	M			3.99	4.23	

Note: Forward voltage measurement allowance is ± 0.1V.

Royal Blue Wavelength Bins

(@ I_F=700mA, T_j=25°C)

Name	Code	λ _p Max (nm)	λ _p Min (nm)
Royal Blue	D0	440	445
	D1	445	450
	D2	450	455
	D3	455	460

Note: Wavelength measurement allowance is ± 2nm

RGBA0 Wavelength Bins

(@ I_F=700mA, T_j=25°C)

Name	Code	λ _d Max(nm)	λ _d Min(nm)
Blue	B1	460	465
	B2	465	470
	B3	470	475
	B4	475	480
	B5	480	485
	B6	485	490
Cyan	C1	490	495
	C2	495	500
	C3	500	505
	C4	505	510
	C5	510	515
Green	G1	515	520
	G2	520	525
	G3	525	530
	G4	530	535
	G5	535	540
	G6	540	545
	G7	545	550

Name	Code	λ _d Max(nm)	λ _d Min(nm)
Amber	A1	584.5	587.0
	A2	587.0	589.5
	A4	589.5	592.0
	A6	592.0	594.5
	A7	594.5	597.0
Red & Orange	R1	605	610
	R2	610	615
	R3	615	620
	R4	620	625
	R5	625	630
	R6	630	635
	R7	635	640

Note: Wavelength measurement allowance is ± 2nm

Radiometric Flux Bins Map (Royal Blue)

(@ I_F=700mA, T_j=25°C)

Bin Code	Min. (mW)	Max.(mW)
0	0	10
1	10	20
2	20	30
3	30	40
4	40	50
5	50	75
6	75	100
7	100	125
8	125	150
9	150	175

Bin Code	Min. (mW)	Max.(mW)
A	175	225
B	225	275
C	275	350
D	350	425
E	425	500
F	500	600
G	600	700
H	700	800
J	800	900
K	900	1000

Luminous Flux Bins Map (RGBA0)

(@ I_F=700mA, T_j=25°C)

BIN CODE	MIN (Lm)	MAX (Lm)
A	8.2	10.7
B	10.7	13.9
C	13.9	18.1
D	18.1	23.5
E	23.5	30
F	30	40
G	40	50
H	50	60
J	60	70
K	70	80
L	80	90
M	90	100
N	100	120
P	120	140

BIN CODE	MIN (Lm)	MAX (Lm)
Q	140	160
R	160	180
S	180	200
T	200	220
U	220	240
V	240	260
W	260	280
X	280	300
Y	300	350
1	350	400
2	400	450
3	450	500
4	500	550
5	550	600

Note: 1.Luminous flux measurement allowance is ± 10%.

2.Radiometric Flux measurement allowance is ± 10%.

5. Part Number

Formation

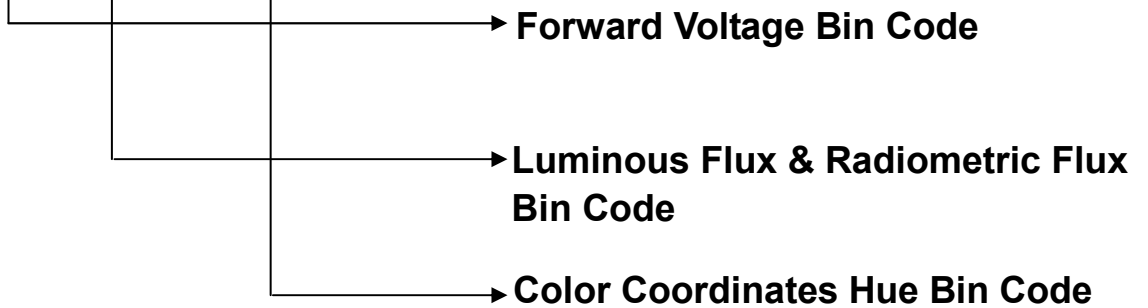
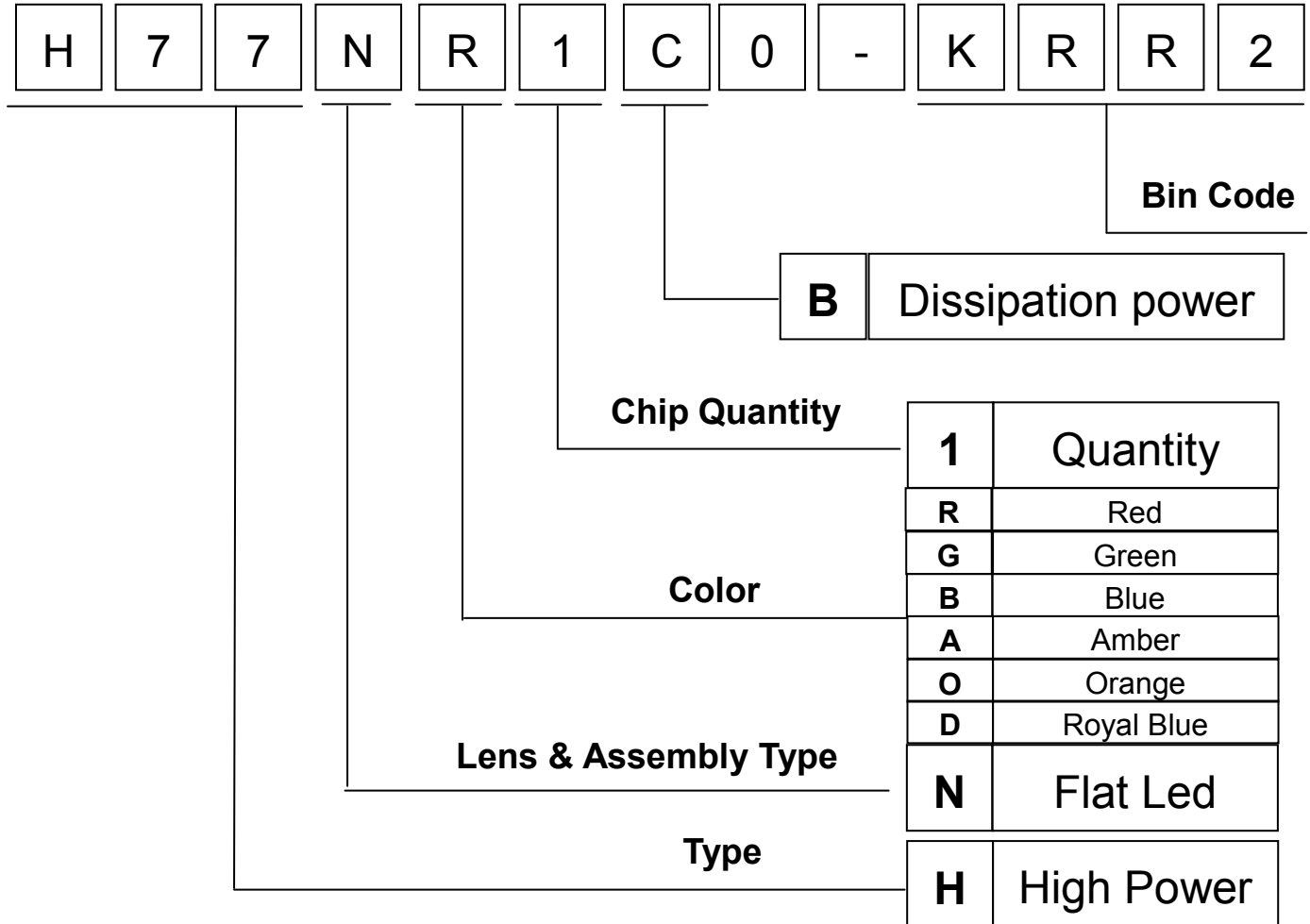

6. Characteristic Diagrams

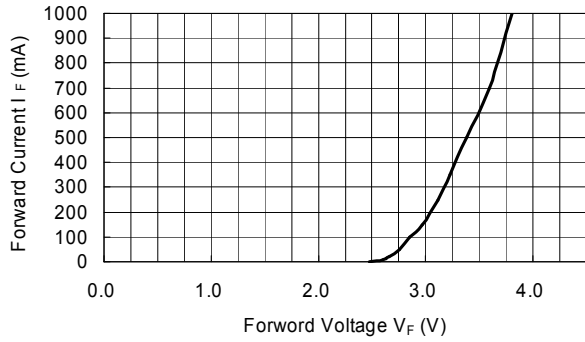

Fig. 1-A Forward Current vs. Forward Voltage:
Blue/ Green/ Royal Blue colors

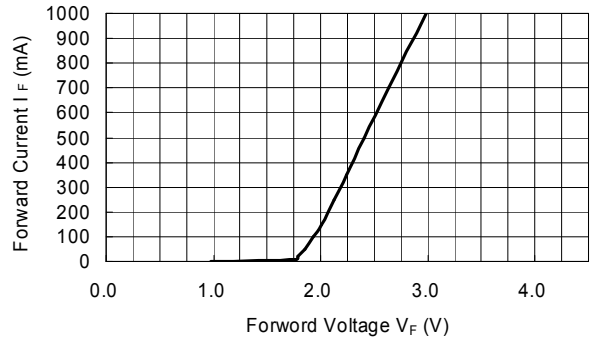

Fig. 1-B Forward Current vs. Forward Voltage:
Red/ Amber/ Orange colors

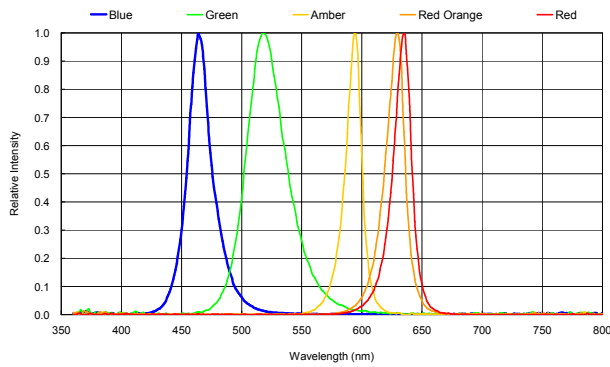

Fig. 2-C Relative Intensity vs. Wavelength:
Single Color

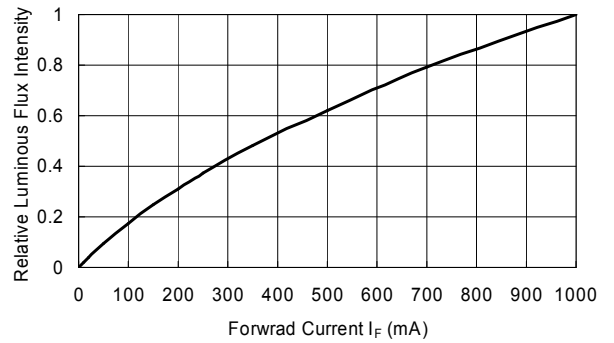
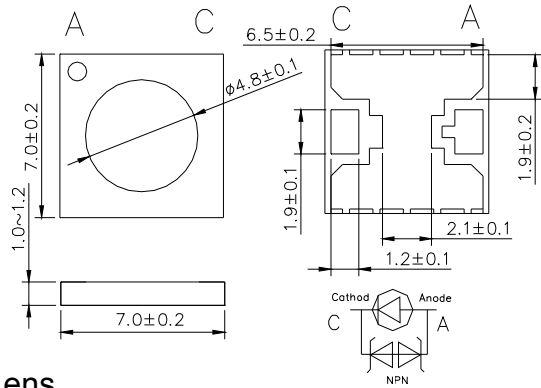

Fig. 3 Relative Intensity VS Forward Current

7. Outline Dimensions (Unit: mm)

Flat Type



120° Lens

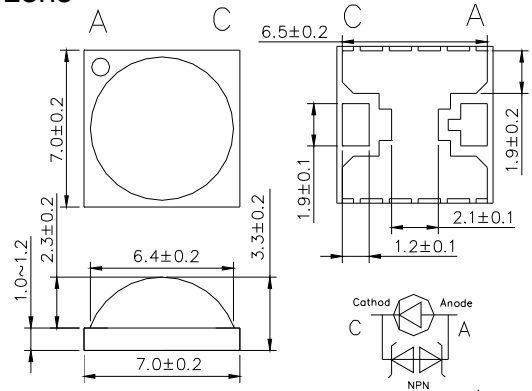

25° Lens

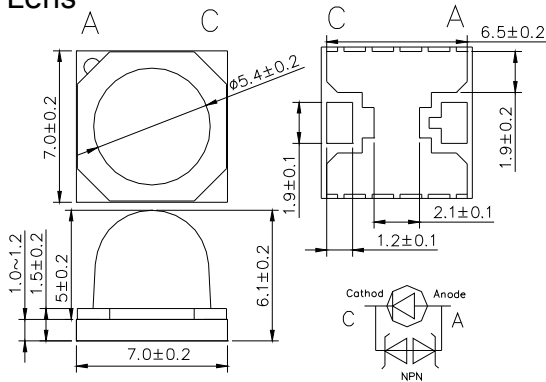

45° Lens

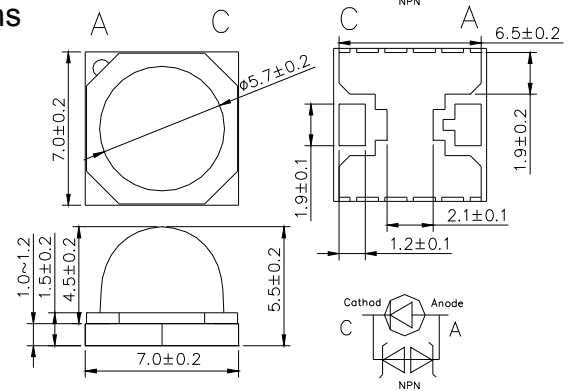

100°/50° Lens

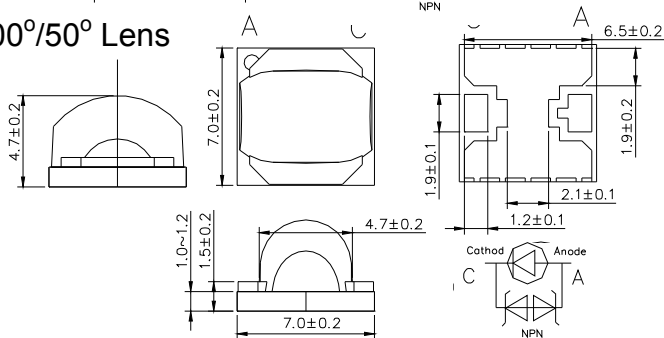

Star

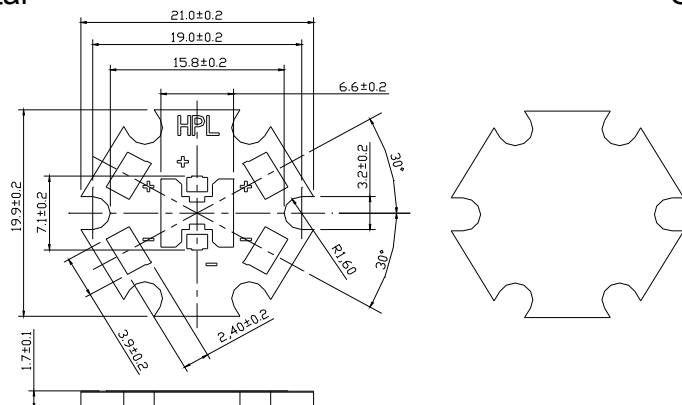

Solder Pad Note: See the caution area

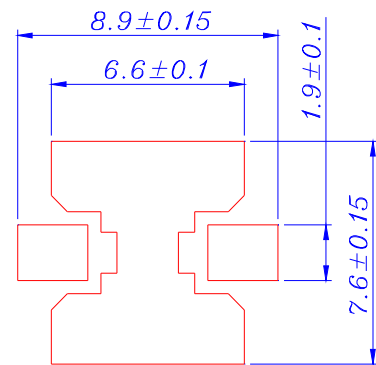

8. Shipping Package Unit : mm

(1) Tapping Dimension Packaging Specification

- **Flat Type :**

- Moisture proof bag.
- 1 Reel/bag.
- Q'ty: 500(MAX)/Reel.

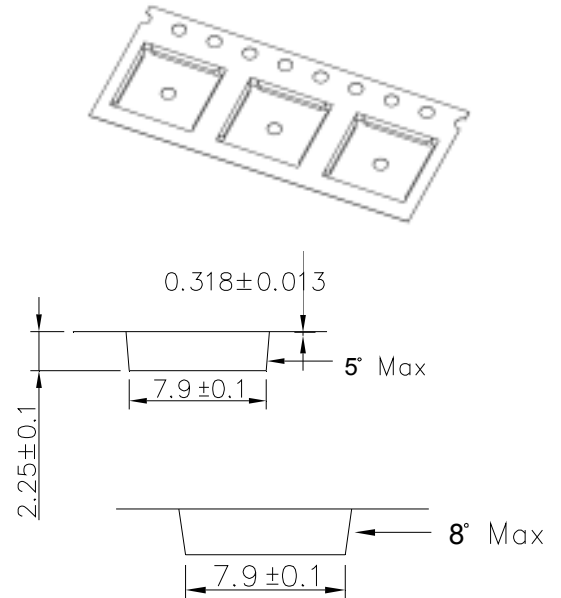
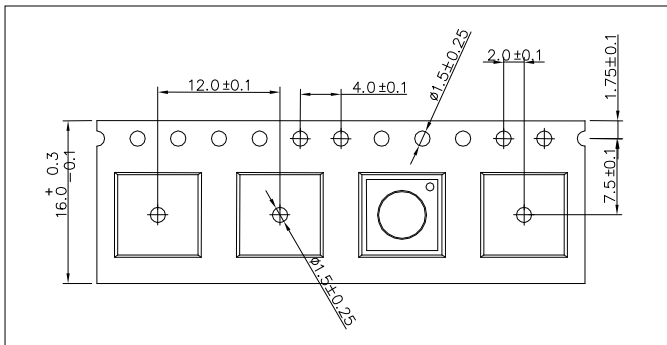

- **With 120 degree Lens:**

- Moisture proof bag.
- 1 Reel/bag.
- Q'ty: 200(MAX)/Reel.

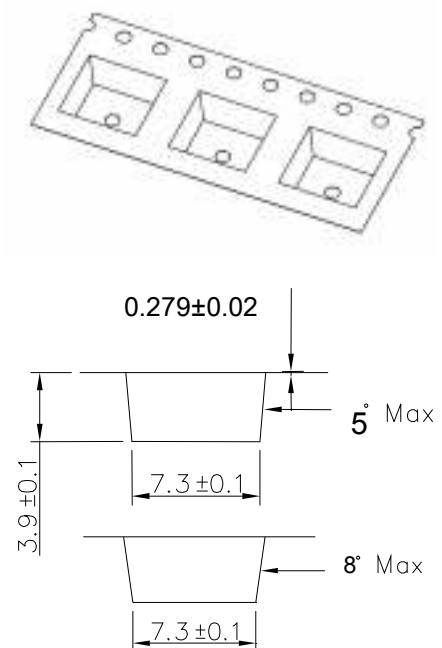
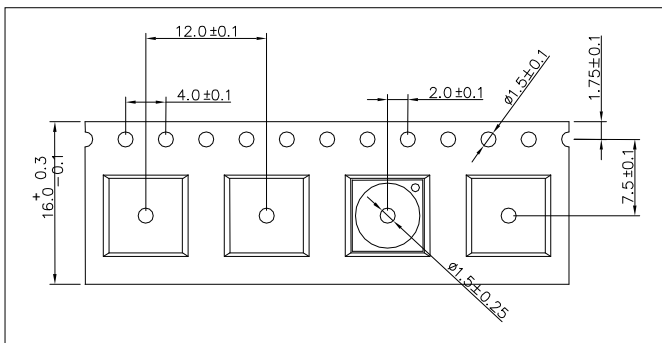

● **With 45, 100/50 degree Lens:**

- Moisture proof bag.
- 1 Reel/bag.
- Q'ty: 150(MAX)/Reel.

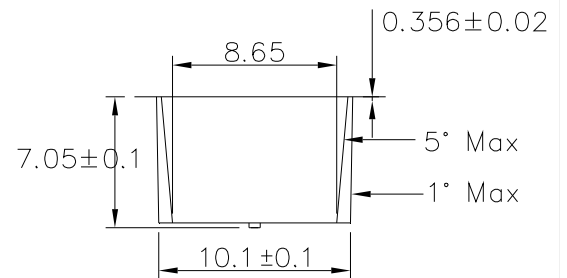
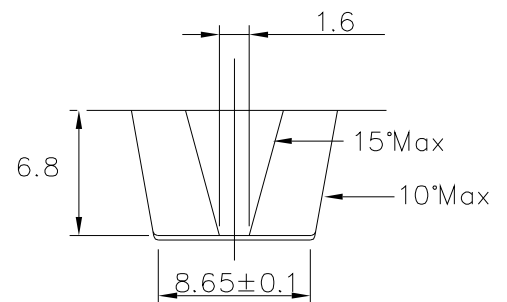
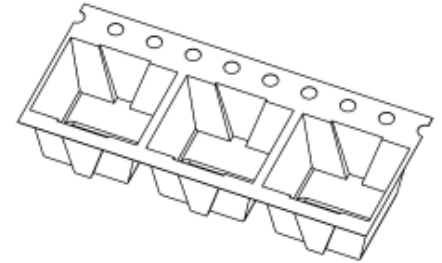
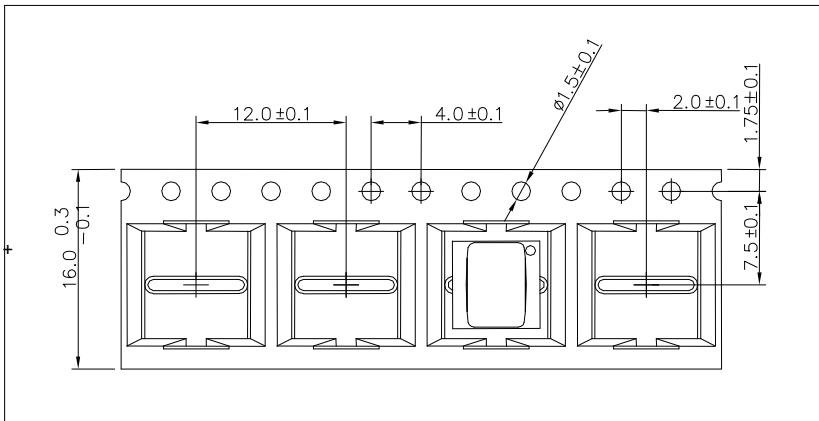

● **With 25 degree Lens & Special Shipping:**

- Moisture proof bag.
- 1 Reel/bag.
- Q'ty: 150(MAX)/Reel.

Dimensions. (Unit: mm)

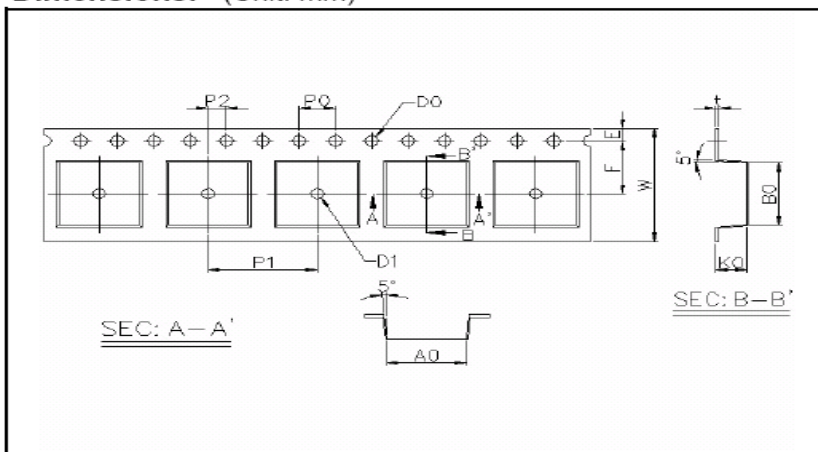

Item	Specification	Tol. (+/-)
W	16.00	± 0.30
E	1.75	± 0.10
F	7.50	± 0.10
D0	1.50	+0.10,-0
D1	1.50	+0.10,-0
P0	4.00	± 0.10
P1	12.00	± 0.10
P2	2.00	± 0.10
P0 x 10	40.00	± 0.20

t	0.35	± 0.05
A0	7.60	± 0.10
B0	7.60	± 0.10
K0	5.30	± 0.10

14/17

HPL-H77XX1C0
Colors: RGBAOD
2007/10

(2) Package

Box Type	Dimensions (mm)	Reel/Box
Small Box (S)	230 × 85 × 265	4 Reel/Box
Middle Box (M)	470 × 265 × 270	24 Reel/Box
Large Box (L)	470 × 435 × 270	40 Reel/Box

Reel Packaging Unit: mm

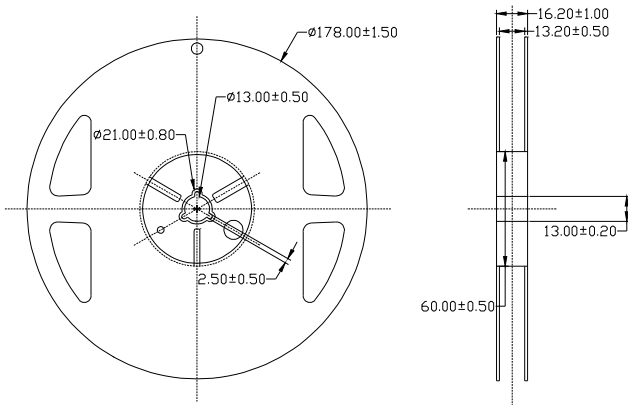

Anti Static Bag

Anti Static Bag :

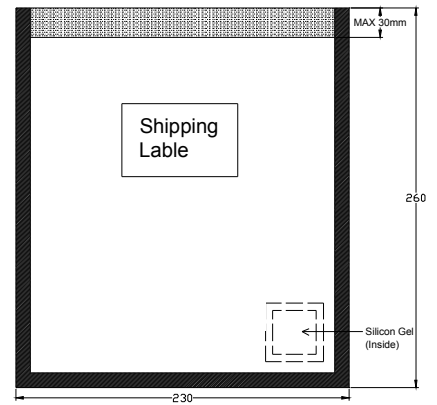

Inside Small

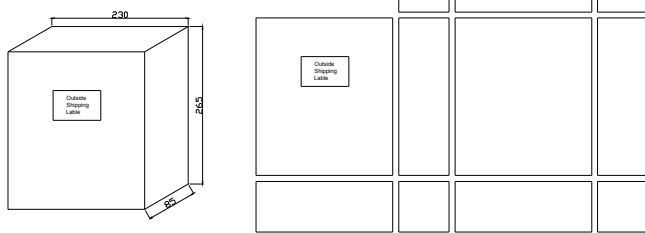

Middle Box

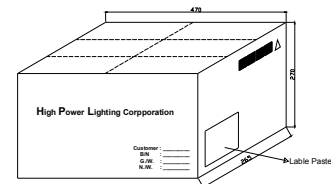
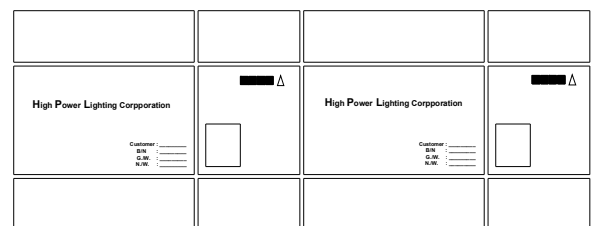

Large Box (Carton)

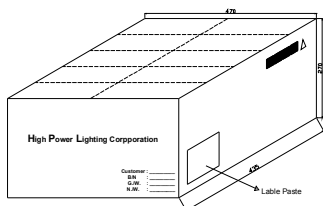
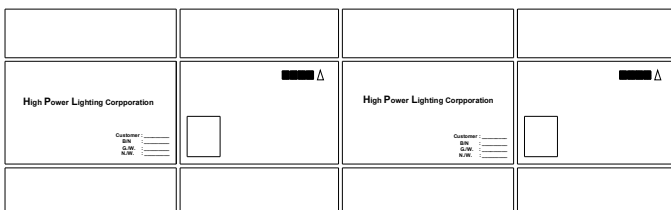

(3) Label Formation

Carton Label

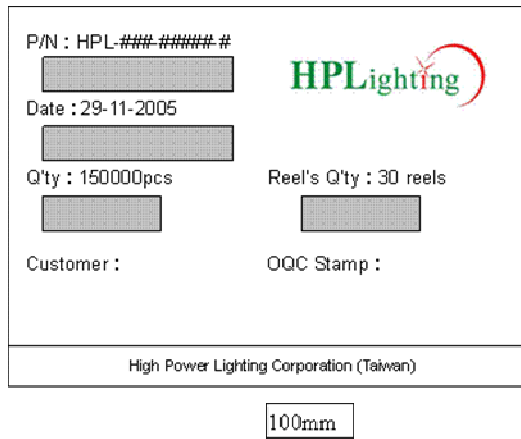

Reel Label

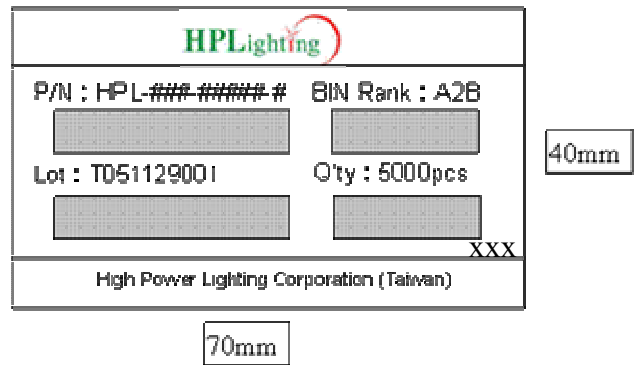

9. Recommended Solder profile

Soldering

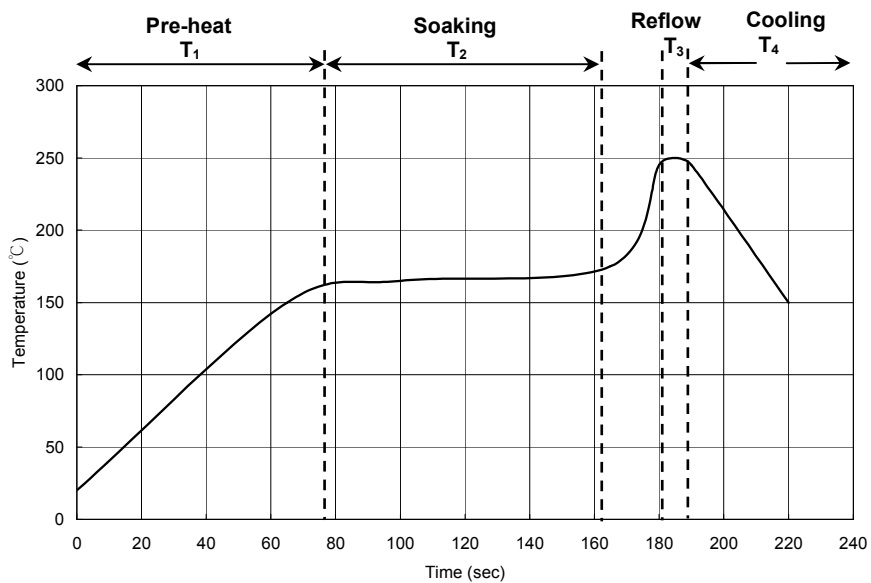

Recommended soldering conditions:

T ₁	Ramp up rate	1.0 ~ 3.0 °C/sec
	Pre-heat time	50 ~ 80 sec
T ₂	Soaking temperature	155 ~ 185 °C
	Dwell time during soaking	60 ~ 120 sec
T ₃	Reflow temperature	240 ~ 250 °C
	Reflow time	Max 10 sec
	Ramp up rate during reflow	1.2 ~ 2.3 °C/sec
T ₄	Cooling	1.0 ~ 6.0 °C/sec

Note: Suggest using Sn96Ag3Cu0.5 lead free solder.

Cleaning

Use alcohol-based cleaning solvents such as isopropyl alcohol to clean the LED if necessary.