

SPECIFICATION

HPL- H40XX1BA

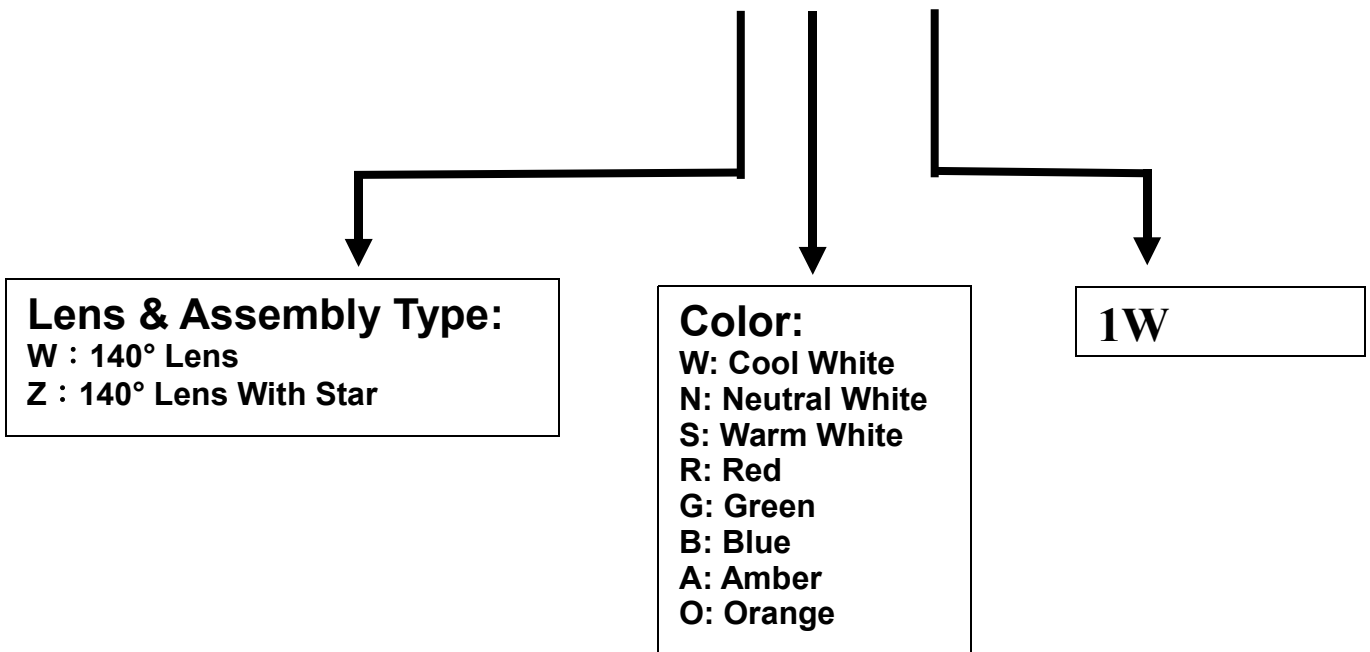

Caution:

Depends on different chips structures, the thermal pad could has a polarity as Anode. To avoid the risk of circuit-fail, **It is strongly recommended to suppose the condition (Anode – thermal pad)** while designing a circuit.

- Part Number Matrix

Type Color	140° Lens	With Star
Cool White	HPL-H40WW1BA	HPL-H40ZW1BA
Neutral White	HPL-H40WN1BA	HPL-H40ZN1BA
Warm White	HPL-H40WS1BA	HPL-H40ZS1BA
Red	HPL-H40WR1BA	HPL-H40ZR1BA
Green	HPL-H40WG1BA	HPL-H40ZG1BA
Blue	HPL-H40WB1BA	HPL-H40ZB1BA
Amber	HPL-H40WA1BA	HPL-H40ZA1BA
Orange	HPL-H40WO1BA	HPL-H40ZO1BA

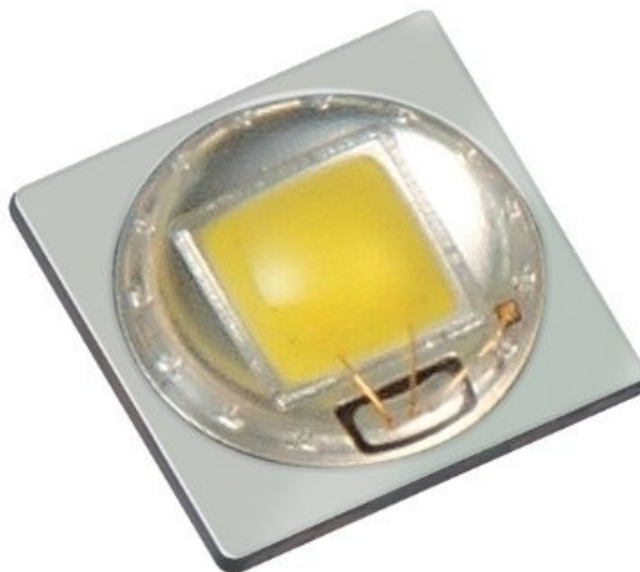

1. Features

- Dimension : 4.0mm(L)×4.0mm(W)×1.7mm(H)
- LED by InGaN or AlInGaP Chip inside
- Good for SMT Process
- All Metal Design Cu PCB

2. Applications

- Signal lighting
- Backlighting
- Interior & exterior automotive lighting
- Decorative and landscape lighting
- Signage and channel letter
- Portable light source
- Decorating and entertainment lighting

3. Absolute Maximum Ratings

(T_j=25°C)

Parameter		Symbol	Rating	Unit
Power Dissipation	Cool-White	P	1.5	W
	Neutral-White		1.5	
	Warm-White		1.5	
	Red		1.05	
	Green		1.5	
	Blue		1.5	
	Amber		1.05	
	Orange		1.05	
Forward Current		IF	350	mA
Forward Pulse Current (1/10 Duty Cycle, 400msec Pulse Width)		IFP	500	mA
Thermal Resistance, Junction-Case		Rth, J-C1	10	°C/W
Reverse Voltage		VR	5	V
LED Junction Temperature		T _j	125	°C
Operating Temperature Range		Topr	-40°C to + 80°C	
Storage Temperature Range		Tstg	-40°C to + 120°C	
Soldering Condition		Tsol	260°C For 5 Seconds	

Note: 1. The thermal resistance value is measured with MCPCB (Star).

4. Initial Electrical/Optical Characteristics

- **Forward Voltage**

(T_j=25°C)

Color	Forward Voltage					
	Symbol	MIN.	TYP.	MAX.	Test Condition	Unit
Cool-White→W	V _F	3.03	3.80	4.23	I _F = 350mA	V
Neutral-White→N	V _F	3.03	3.80	4.23	I _F = 350mA	V
Warm-White→S	V _F	3.03	3.80	4.23	I _F = 350mA	V
Red→R	V _F	1.83	2.50	3.03	I _F = 350mA	V
Green→G	V _F	3.03	3.80	4.23	I _F = 350mA	V
Blue→B	V _F	3.03	3.80	4.23	I _F = 350mA	V
Amber→A	V _F	1.83	2.50	3.03	I _F = 350mA	V
Orange→O	V _F	1.83	2.50	3.03	I _F = 350mA	V

- **Reverse Current**

(T_j=25°C)

Color	Reverse Current					
	Symbol	MIN.	TYP.	MAX.	Test Condition	Unit
Cool-White→W	I _R	-	-	100	V _R = 5V	μA
Neutral-White→N	I _R	-	-	100	V _R = 5V	μA
Warm-White→S	I _R	-	-	100	V _R = 5V	μA
Red→R	I _R	-	-	100	V _R = 5V	μA
Green→G	I _R	-	-	100	V _R = 5V	μA
Blue→B	I _R	-	-	100	V _R = 5V	μA
Amber→A	I _R	-	-	100	V _R = 5V	μA
Orange→O	I _R	-	-	100	V _R = 5V	μA

● **View Angle**

Wavelength	Viewing Angle			
	Symbol	Lens 140°	Test Condition	Unit
All	$2\theta_{1/2}$	140°	$I_F = 350\text{mA}$	degree

● **Luminous Flux**

($T_j=25^\circ\text{C}$)

Color	Luminous Flux					
	Symbol	MIN.	TYP.	MAX.	Test Condition	Unit
Cool-White→W	Φ_v	-	75	-	$I_F = 350\text{mA}$	lm
Neutral-White→N	Φ_v	-	60	-	$I_F = 350\text{mA}$	lm
Warm-White→S	Φ_v	-	50	-	$I_F = 350\text{mA}$	lm
Red→R	Φ_v	-	35	-	$I_F = 350\text{mA}$	lm
Green→G	Φ_v	-	55	-	$I_F = 350\text{mA}$	lm
Blue→B	Φ_v	-	10	-	$I_F = 350\text{mA}$	lm
Amber→A	Φ_v	-	34	-	$I_F = 350\text{mA}$	lm
Orange→O	Φ_v	-	38	-	$I_F = 350\text{mA}$	lm

● **Radiometric Power**

($T_j=25^\circ\text{C}$)

Color	Luminous Flux					
	Symbol	MIN.	TYP.	MAX.	Test Condition	Unit
Blue ¹	Φ_v	-	200/180	-	$I_F = 350\text{mA}$	mW

• **Color Temperature or Dominate wavelength** (T_j=25°C)

Color	Color Temperature or Dominate Wavelength					
	Symbol	MIN.	TYP.	MAX.	Test Condition	Unit
Cool-White→W	CCT	4500	5650	10000	IF = 350mA	K
Neutral-White→N	CCT	3500	4000	4500	IF = 350mA	K
Warm-White→S	CCT	2670	3000	3500	IF = 350mA	K
Red→R	λ _d	620	-	630	IF = 350mA	nm
Green→G	λ _d	520	-	530	IF = 350mA	nm
Blue ¹ →B	λ _d	460	-	475	IF = 350mA	nm
Amber→A	λ _d	584.5	-	594.5	IF = 350mA	nm
Orange→O	λ _d	610	-	620	IF = 350mA	nm

Note: 1. Royal Blue Products: Wavelength defined is Peak Wavelength (λ_p = 445 ~ 455nm).

• **Color rendering Index (CRI, Ra value)** (T_j=25°C)

Color	Color Temperature or Dominate Wavelength					
	Symbol	MIN.	TYP.	MAX.	Test Condition	Unit
Cool-White→W	Ra	65	70	-	IF = 350mA	-
Neutral-White→N		70	75	-	IF = 350mA	-
Warm-White→S		75	80	-	IF = 350mA	-

- **Typical Radiation Pattern**

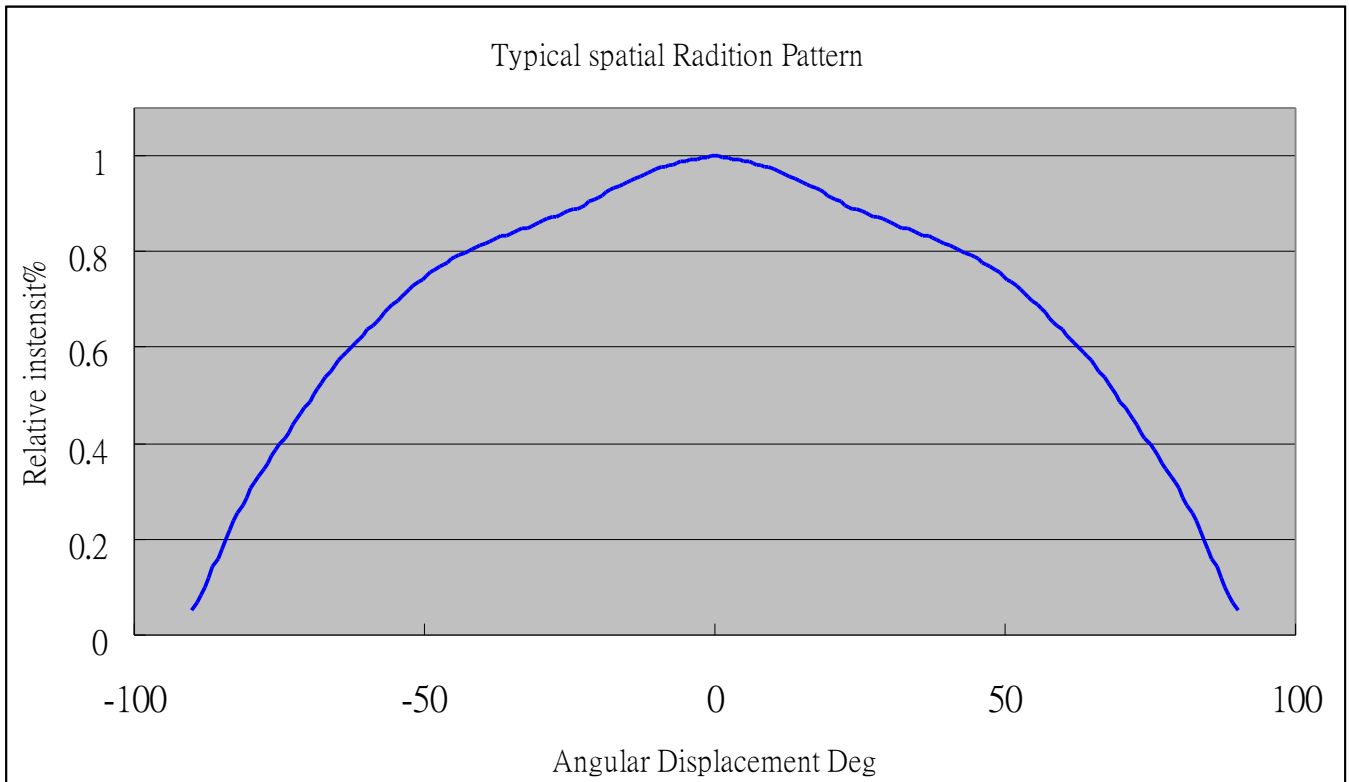

Fig.4A Typical Representative Spatial Radiation Pattern for Cool-White, Neutral-White and Warm-White ..

• **Bin Code List for Reference**

(T_j=25°C)

Item	Bin Code	Symbol	Condition	Min.	Max.	Unit
Forward Voltage ¹	C	V _F	I _F = 350 [mA]	1.83	2.07	V
	D			2.07	2.31	
	E			2.31	2.55	
	F			2.55	2.79	
	G			2.79	3.03	
	H			3.03	3.27	
	J			3.27	3.51	
	K			3.51	3.75	
	L			3.75	3.99	
	M			3.99	4.23	
Luminous Flux ²	A	Φ _v	I _F = 350 [mA]	8.2	10.7	lm
	B			10.7	13.9	
	C			13.9	18.1	
	D			18.1	23.5	
	E			23.5	30	
	F			30	40	
	G			40	50	
	H			50	60	
	J			60	70	
	K			70	80	
	L			80	90	
	M			90	100	
	N			100	120	
	P			120	140	
Q	140	160				

Note: 1. Forward voltage measurement allowance is ± 0.1V.

2. Luminous flux measurement allowance is ± 10%.

● Hue Bin Code List for Reference

Cool-White→W color

Bin Code	X	Y	CCT(K)
YO	0.2742	0.3007	7000~10000
	0.3031	0.3327	
	0.3076	0.3108	
	0.2830	0.2838	
YA	0.2830	0.2838	6300~7000
	0.3076	0.3108	
	0.3112	0.2932	
	0.2899	0.2703	
XM	0.3011	0.3422	6300~7000
	0.3136	0.3550	
	0.3148	0.3444	
	0.3031	0.3327	
XN	0.3031	0.3327	6300~7000
	0.3148	0.3444	
	0.3160	0.3332	
	0.3052	0.3224	
XO	0.3052	0.3224	6300~7000
	0.3160	0.3332	
	0.3175	0.3204	
	0.3076	0.3108	
XP	0.3076	0.3108	6300~7000
	0.3175	0.3204	
	0.3196	0.3013	
	0.3112	0.2932	
WM	0.3136	0.3550	5650~6300
	0.3286	0.3690	
	0.3288	0.3569	
	0.3148	0.3444	

Bin Code	X	Y	CCT(K)
WN	0.3148	0.3444	5650~6300
	0.3288	0.3569	
	0.3290	0.3451	
	0.3160	0.3332	
WO	0.3160	0.3332	5650~6300
	0.3290	0.3451	
	0.3292	0.3313	
	0.3175	0.3204	
WP	0.3175	0.3204	5650~6300
	0.3292	0.3313	
	0.3294	0.3202	
	0.3186	0.3102	
WQ	0.3186	0.3102	5650~6300
	0.3294	0.3202	
	0.3295	0.3105	
	0.3196	0.3013	
VM	0.3286	0.3690	5000~5650
	0.3481	0.3856	
	0.3469	0.3717	
	0.3288	0.3569	
VN	0.3288	0.3569	5000~5650
	0.3469	0.3717	
	0.3458	0.3592	
	0.3290	0.3451	
VO	0.3290	0.3451	5000~5650
	0.3458	0.3592	
	0.3444	0.3442	
	0.3292	0.3313	

Bin Code	X	Y	CCT(K)
VP	0.3292	0.3313	5000~5650
	0.3444	0.3442	
	0.3434	0.3320	
	0.3294	0.3202	
UM	0.3481	0.3856	4500~5000
	0.3673	0.4003	
	0.3642	0.3829	
	0.3469	0.3717	
UN	0.3469	0.3717	4500~5000
	0.3642	0.3829	
	0.3622	0.3716	
	0.3458	0.3592	
UO	0.3458	0.3592	4500~5000
	0.3622	0.3716	
	0.3594	0.3557	
	0.3444	0.3442	
UP	0.3444	0.3442	4500~5000
	0.3594	0.3557	
	0.3571	0.3426	
	0.3434	0.3320	

Cool-White Bin Structure

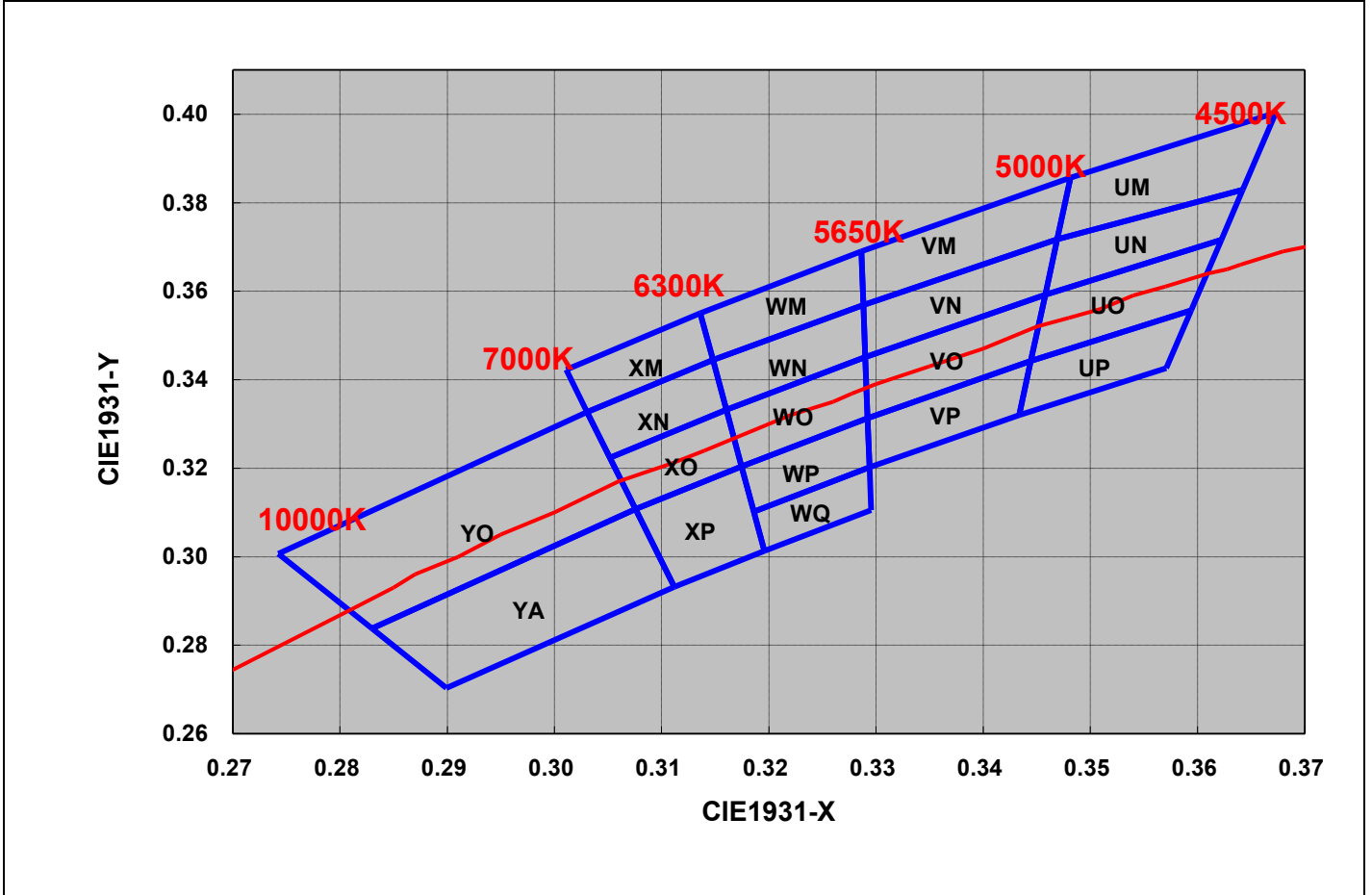

Fig. 4B Cool-White Bin Structure



Neutral-White→N color

Bin Code	X	Y	CCT(K)
TM	0.3673	0.4003	4100~4500
	0.3860	0.4130	
	0.3811	0.3937	
	0.3642	0.3829	
TN	0.3642	0.3829	
	0.3811	0.3937	
	0.3783	0.3825	
	0.3622	0.3716	
TO	0.3622	0.3716	
	0.3783	0.3825	
	0.3741	0.3658	
	0.3594	0.3557	
TP	0.3594	0.3557	
	0.3741	0.3658	
	0.3706	0.3520	
	0.3571	0.3426	

Bin Code	X	Y	CCT(K)
SM	0.3860	0.4130	3800~4100
	0.4023	0.4228	
	0.3963	0.4035	
	0.3811	0.3937	
SN	0.3811	0.3937	
	0.3963	0.4035	
	0.3924	0.3909	
	0.3783	0.3825	
SO	0.3783	0.3825	
	0.3924	0.3909	
	0.3871	0.3739	
	0.3741	0.3658	
SP	0.3741	0.3658	
	0.3871	0.3739	
	0.3826	0.3595	
	0.3706	0.3520	

Bin Code	X	Y	CCT(K)
RM	0.4023	0.4228	3500~3800
	0.4209	0.4326	
	0.4148	0.4161	
	0.3963	0.4035	
RN	0.3963	0.4035	
	0.4148	0.4161	
	0.4086	0.3995	
	0.3924	0.3909	
RO	0.3924	0.3909	
	0.4086	0.3995	
	0.4021	0.3822	
	0.3871	0.3739	
RP	0.3871	0.3739	
	0.4021	0.3822	
	0.3966	0.3673	
	0.3826	0.3595	

Neutral-White Bin Structure

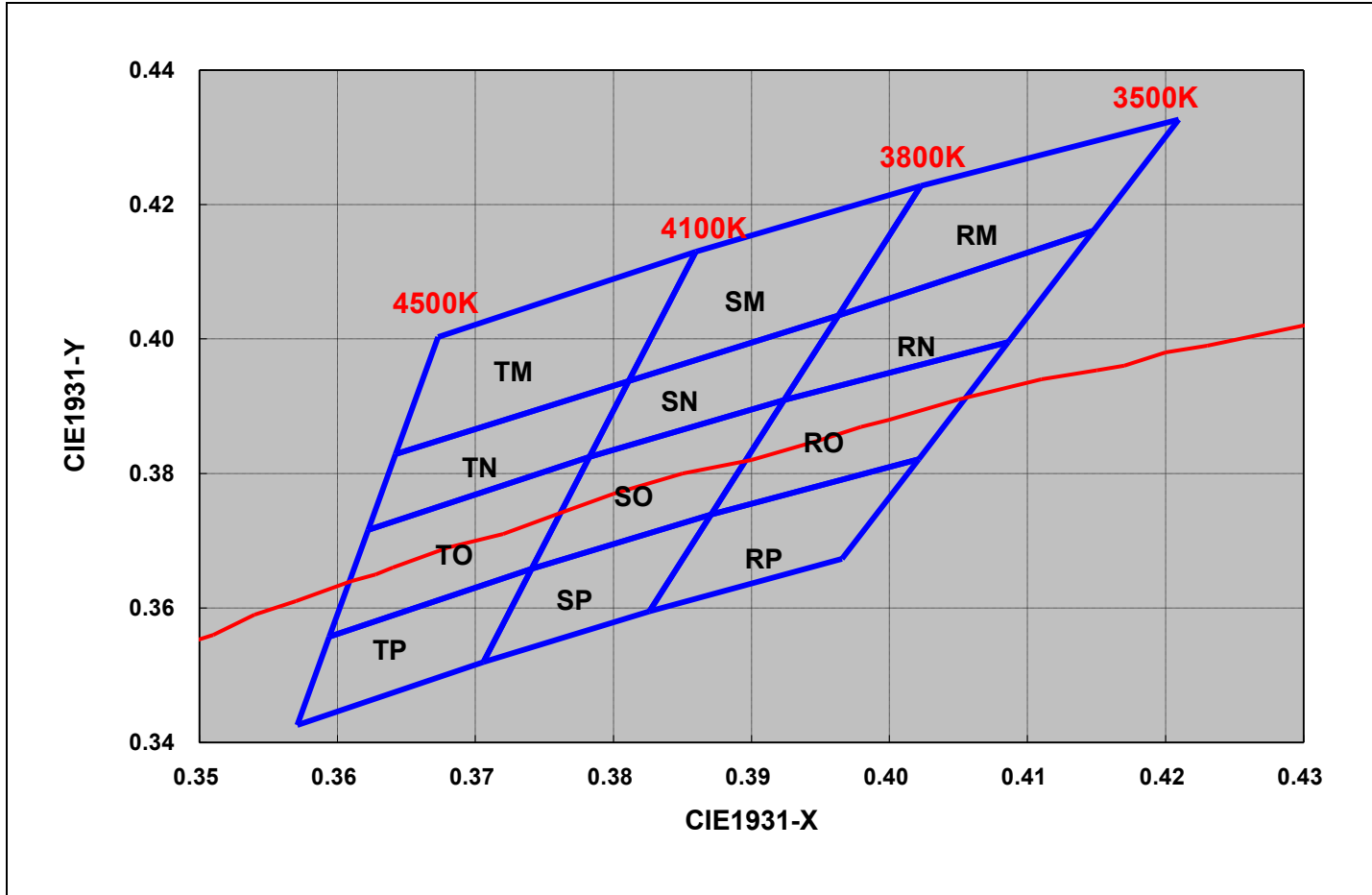

Fig. 4C Neutral-White Bin Structure.



Warm-white→S color

Bin Code	X	Y	CCT(K)
QM	0.4209	0.4326	3250~3500
	0.4385	0.4404	
	0.4312	0.4234	
	0.4148	0.4161	
QN	0.4148	0.4161	3000~3250
	0.4312	0.4234	
	0.4240	0.4065	
	0.4086	0.3995	
QO	0.4086	0.3995	3000~3250
	0.4240	0.4065	
	0.4165	0.3890	
	0.4021	0.3822	
QP	0.4021	0.3822	3000~3250
	0.4165	0.3890	
	0.4100	0.3738	
	0.3966	0.3673	
PM	0.4385	0.4404	3000~3250
	0.4538	0.4460	
	0.4456	0.4287	
	0.4312	0.4234	
PN	0.4312	0.4234	3000~3250
	0.4456	0.4287	
	0.4376	0.4116	
	0.4240	0.4065	

Bin Code	X	Y	CCT(K)
PO	0.4240	0.4065	3000~3250
	0.4376	0.4116	
	0.4294	0.3943	
	0.4165	0.3890	
PP	0.4165	0.3890	2850~3000
	0.4294	0.3943	
	0.4221	0.3790	
	0.4100	0.3738	
NM	0.4538	0.4460	2850~3000
	0.4705	0.4508	
	0.4614	0.4333	
	0.4456	0.4287	
NN	0.4456	0.4287	2850~3000
	0.4614	0.4333	
	0.4525	0.4162	
	0.4376	0.4116	
NO	0.4376	0.4116	2850~3000
	0.4525	0.4162	
	0.4436	0.3991	
	0.4294	0.3943	
NP	0.4294	0.3943	2850~3000
	0.4436	0.3991	
	0.4356	0.3837	
	0.4221	0.3790	

Bin Code	X	Y	CCT(K)
MM	0.4705	0.4508	2670~2850
	0.4866	0.4542	
	0.4767	0.4366	
	0.4614	0.4333	
MN	0.4614	0.4333	2670~2850
	0.4767	0.4366	
	0.4671	0.4196	
	0.4525	0.4162	
MO	0.4525	0.4162	2670~2850
	0.4671	0.4196	
	0.4577	0.4029	
	0.4436	0.3991	
MP	0.4436	0.3991	2670~2850
	0.4577	0.4029	
	0.4490	0.3875	
	0.4356	0.3837	

Warm-White Bin Structure

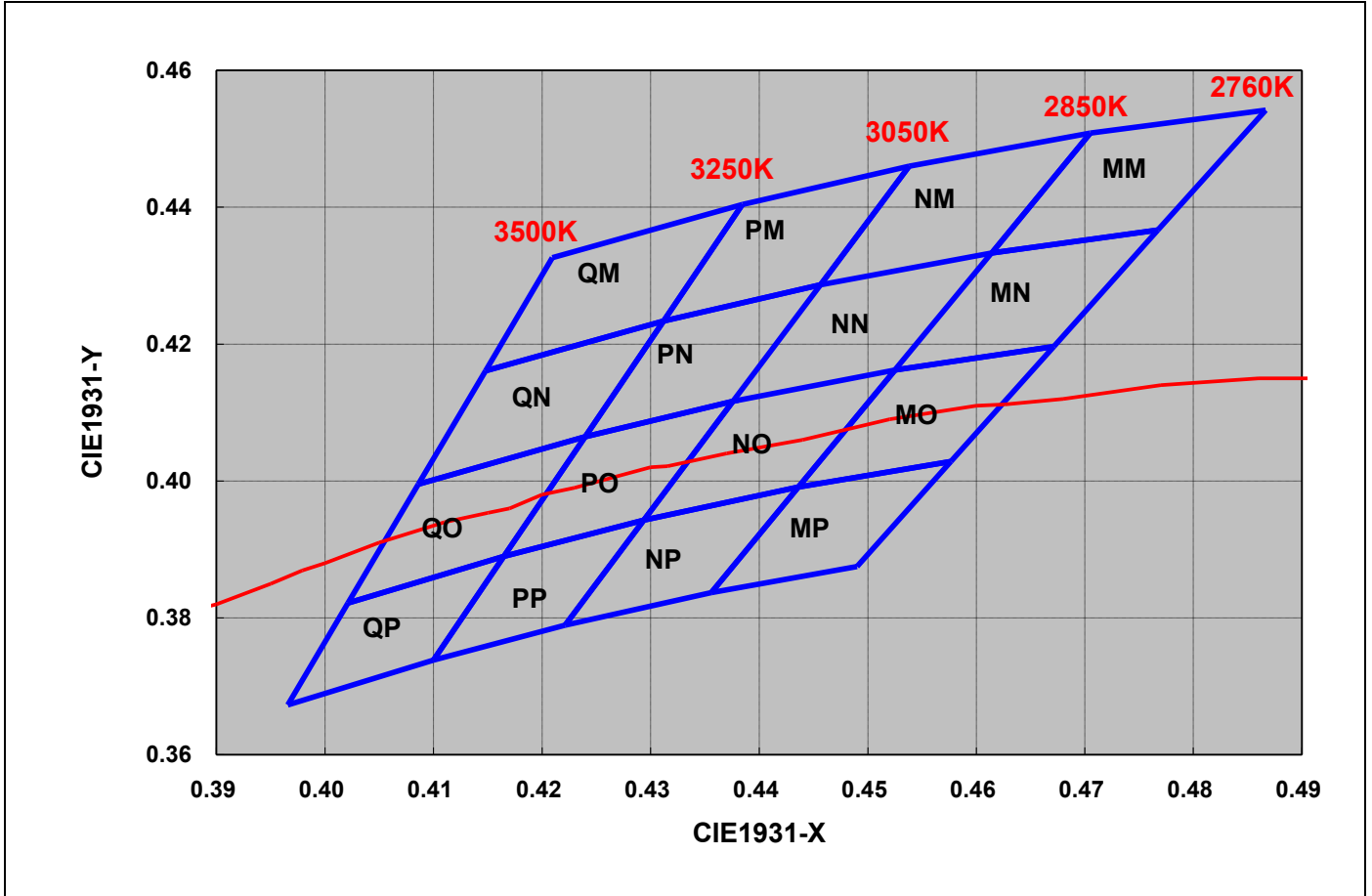

Fig. 4D Warm-White Bin Structure.

Note: The CIE1931 x, y color coordinates measurement allowance is ± 0.01 .

● Hue Bin Specification for Red, Green, Blue, Amber, Orange

Name	Code	λ_p Max (nm)	λ_p Min (nm)
Royal Blue	D0	440	445
	D1	445	450
	D2	450	455
	D3	455	460
Name	Code	λ_d Max(nm)	λ_d Min(nm)
Blue	B1	460	465
	B2	465	470
	B3	470	475
	B4	475	480
	B5	480	485
	B6	485	490
Cyan	C1	490	495
	C2	495	500
	C3	500	505
	C4	505	510
	C5	510	515

Name	Code	λ_d Max(nm)	λ_d Min(nm)	
Green	G1	515	520	
	G2	520	525	
	G3	525	530	
	G4	530	535	
	G5	535	540	
	G6	540	545	
	G7	545	550	
Amber	A1	584.5	587	
	A2	587	589.5	
	A4	589.5	592	
	A6	592	594.5	
	A7	594.5	597	
	Red & Orange	R1	605	610
		R2	610	615
R3		615	620	
R4		620	625	
R5		625	630	
R6		630	635	
R7		635	640	

Note: Wavelength measurement allowance is ± 2 nm

5. Part Number Formation

H 4 0 W W 1 B A - K L W O

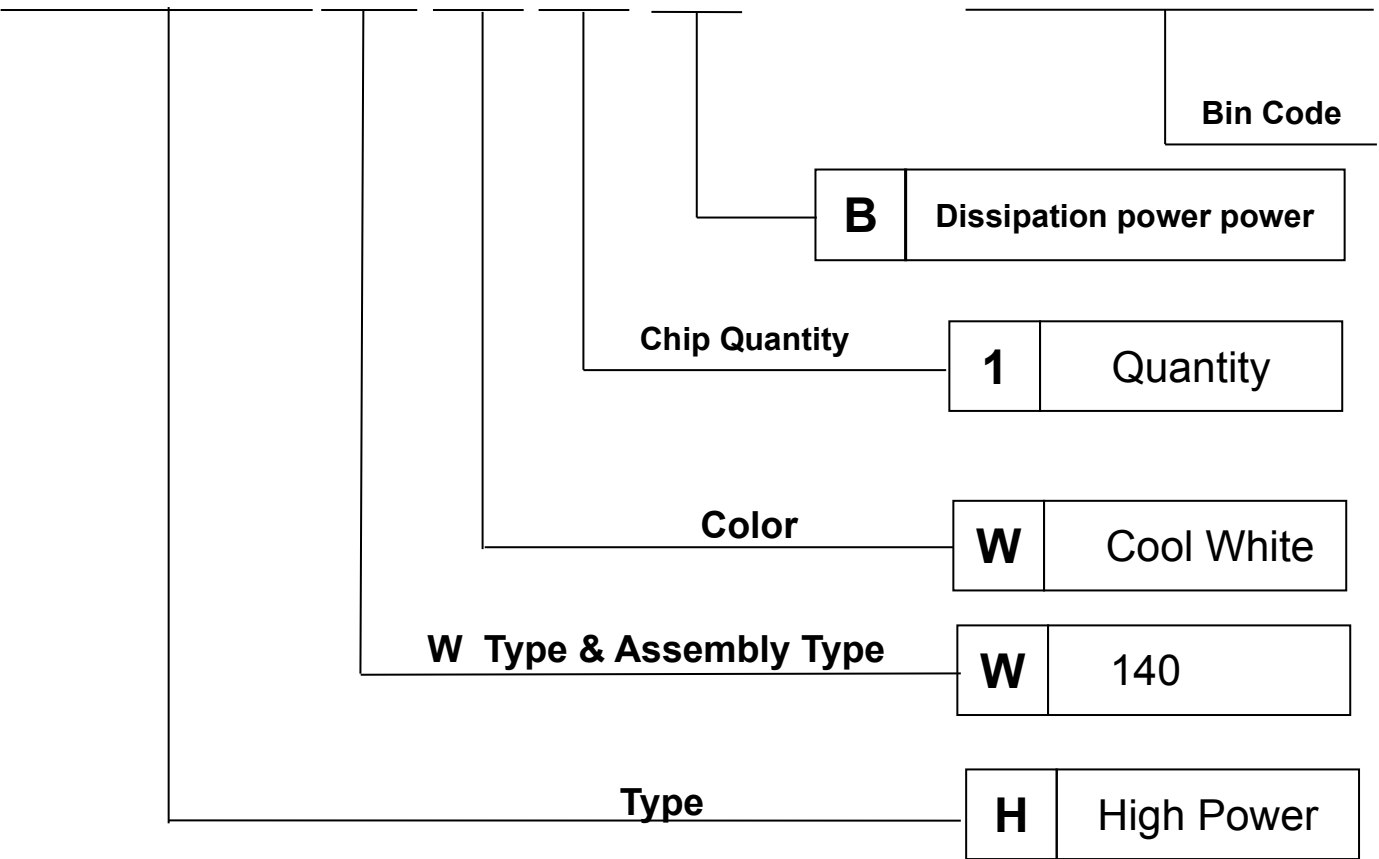

K L W O

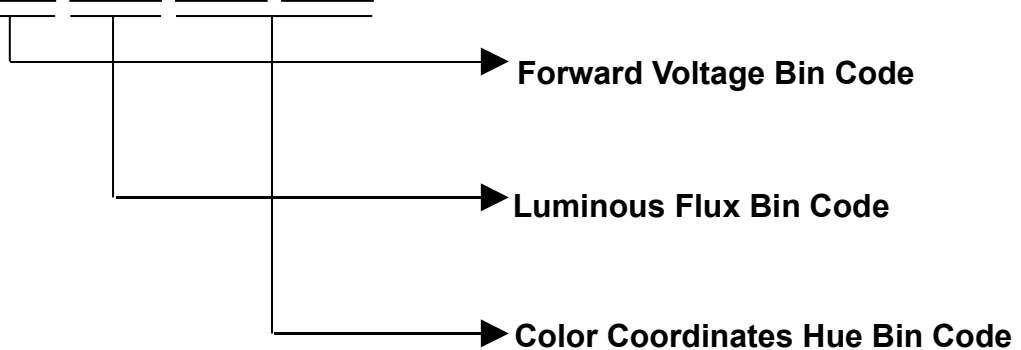

6. Characteristic Diagram

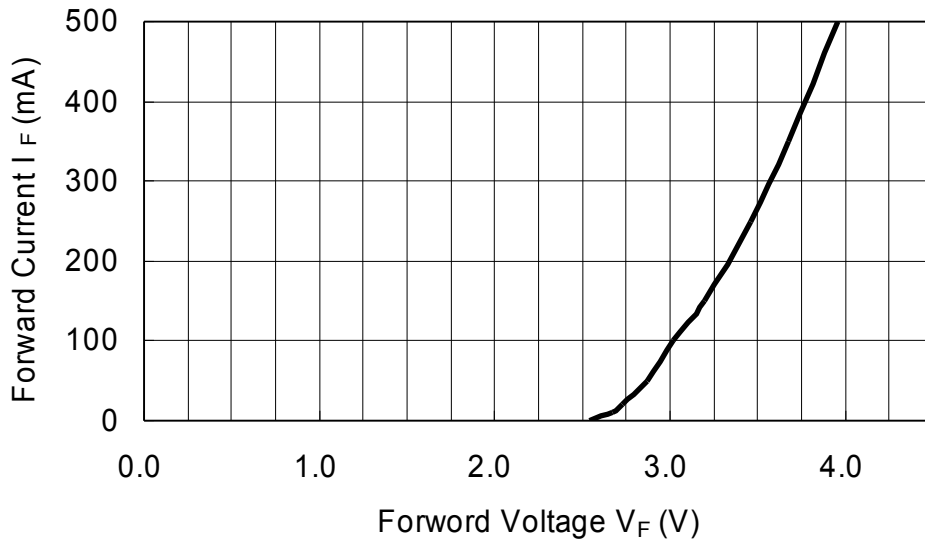

Fig. 6A Forward Current vs. Forward Voltage: Cool White/ Neutral White/ Warm White / Blue/ Green color.

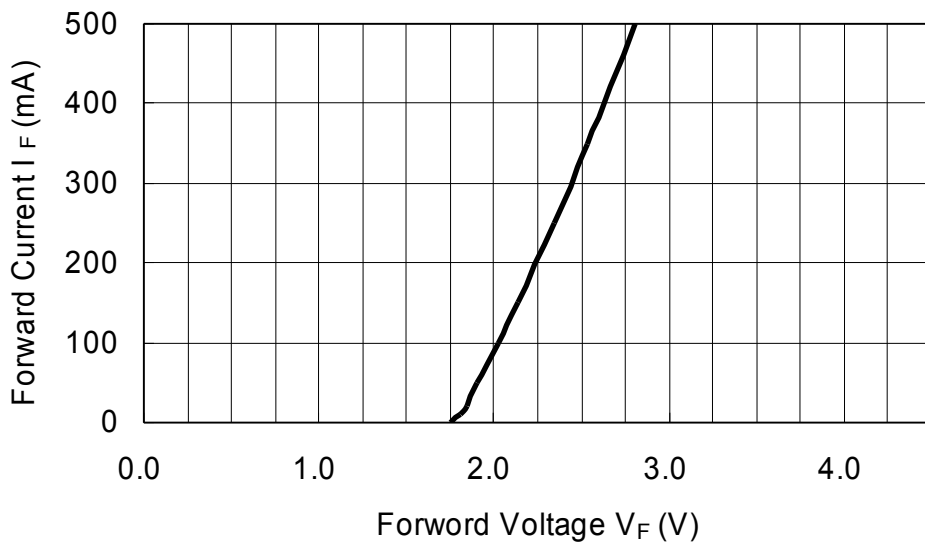

Fig. 6B Forward Current vs. Forward Voltage: Red/Amber/Orange color.

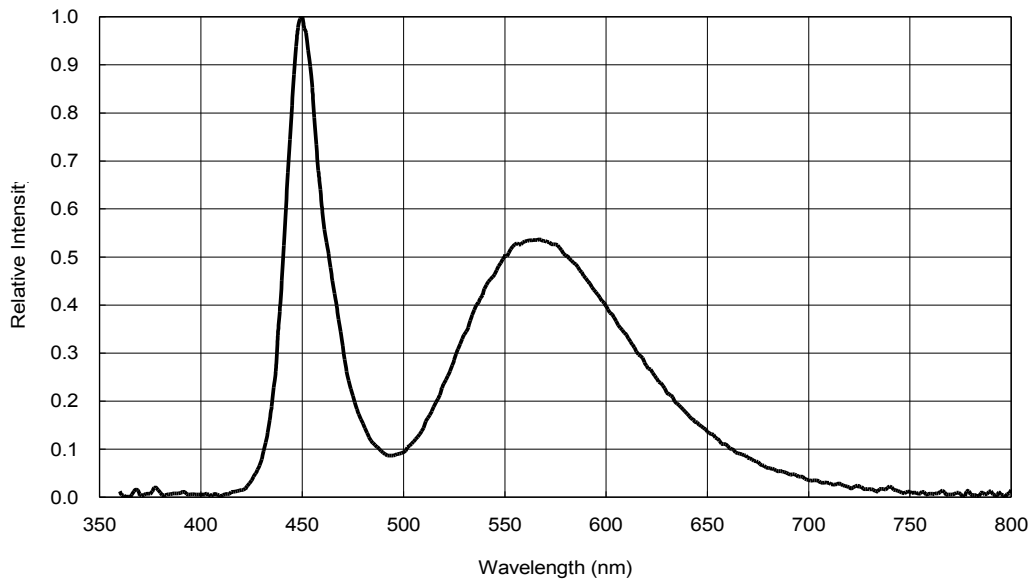

Fig. 6C Relative Intensity vs. Wavelength: Cool White.

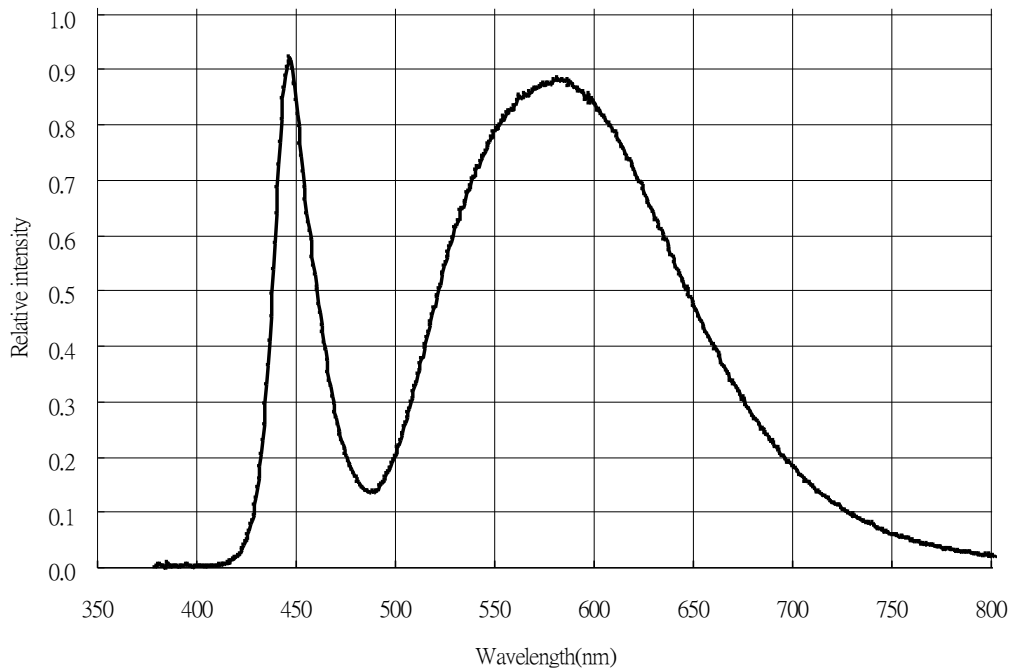

Fig. 6D Relative Intensity vs. Wavelength: Nature White.

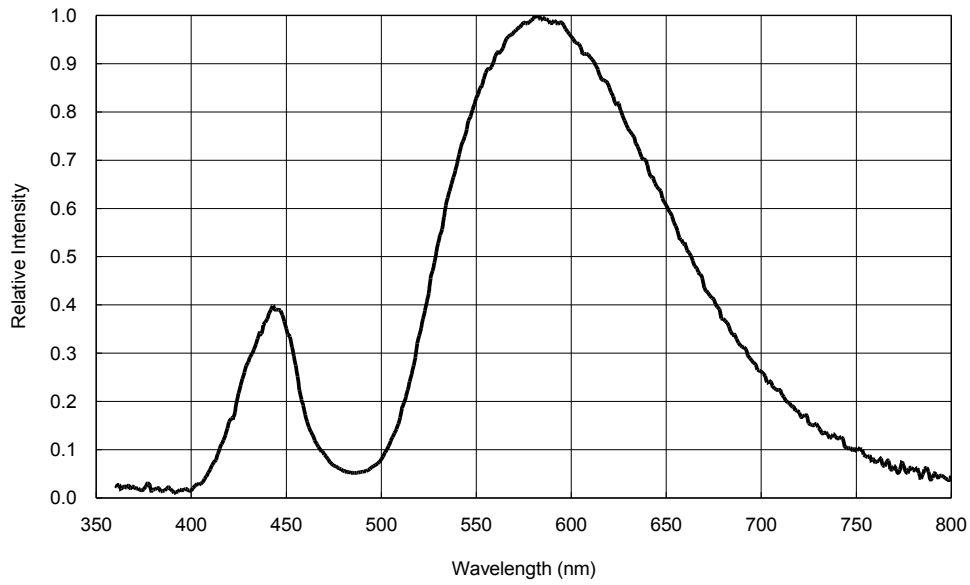

Fig. 6E Relative Intensity vs. Wavelength: Warm White.

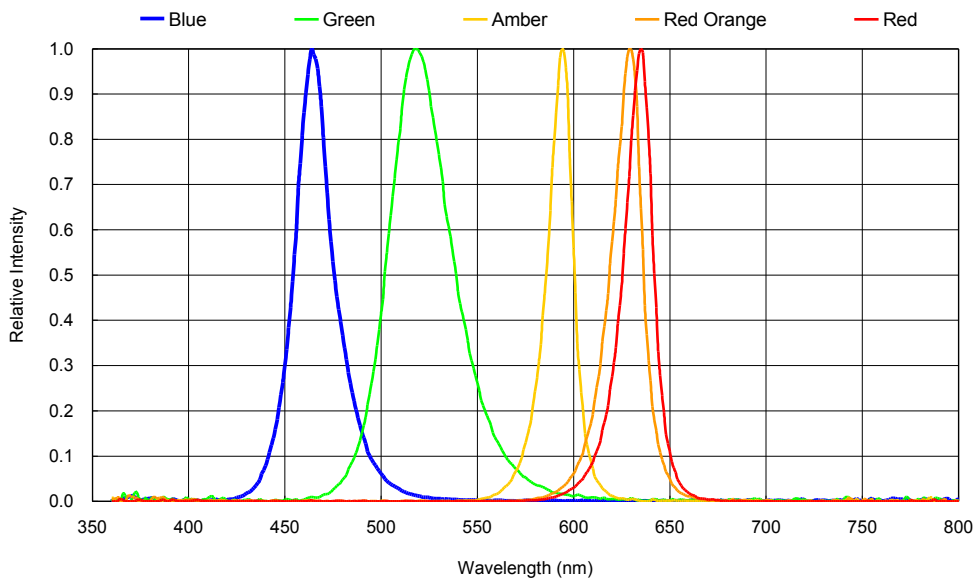

Fig. 6F Relative Intensity vs. Wavelength: Single Color.

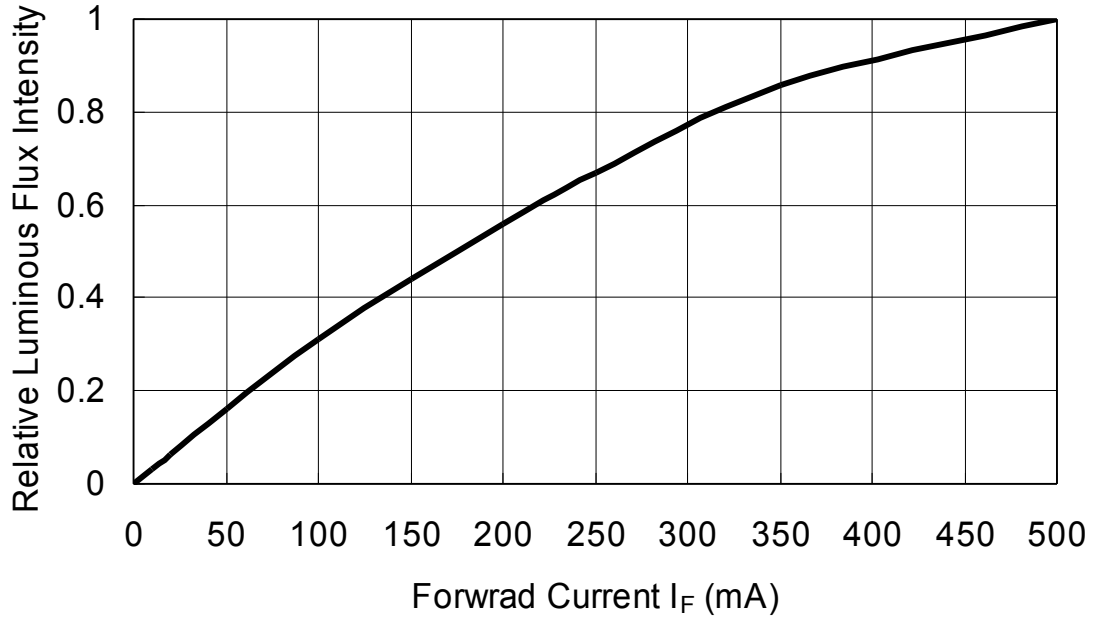

Fig. 6G Relative Intensity vs. Forward Current.

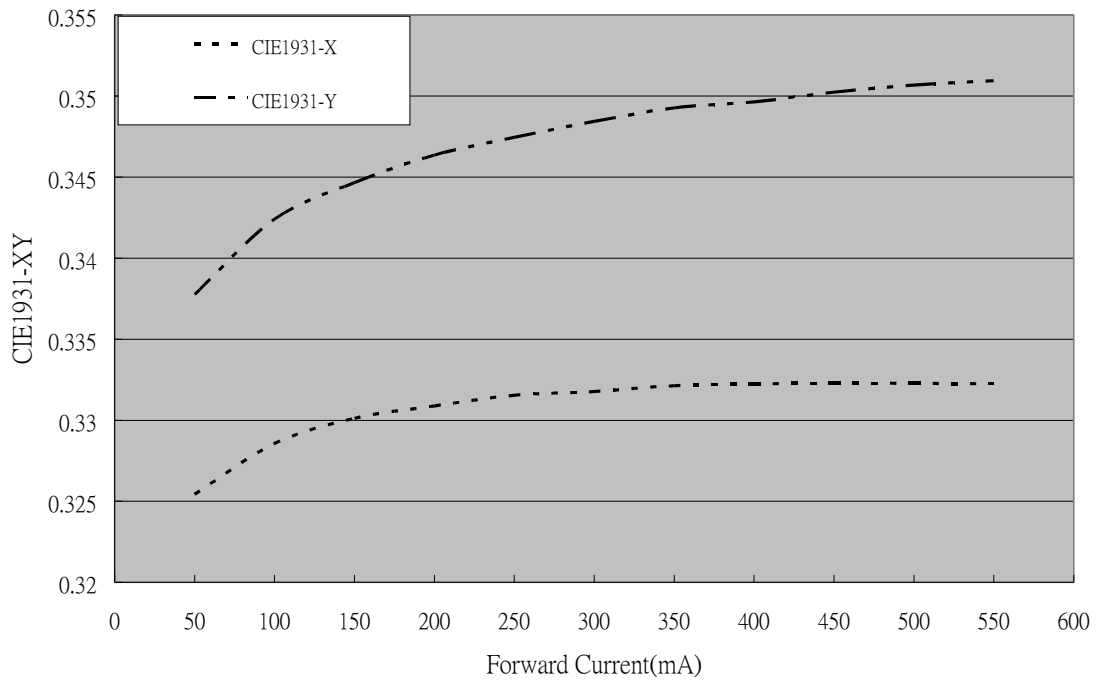

Fig. 6H Forward Current vs. CIE1931 X, Y.

7. Outline Dimension

Unit : mm

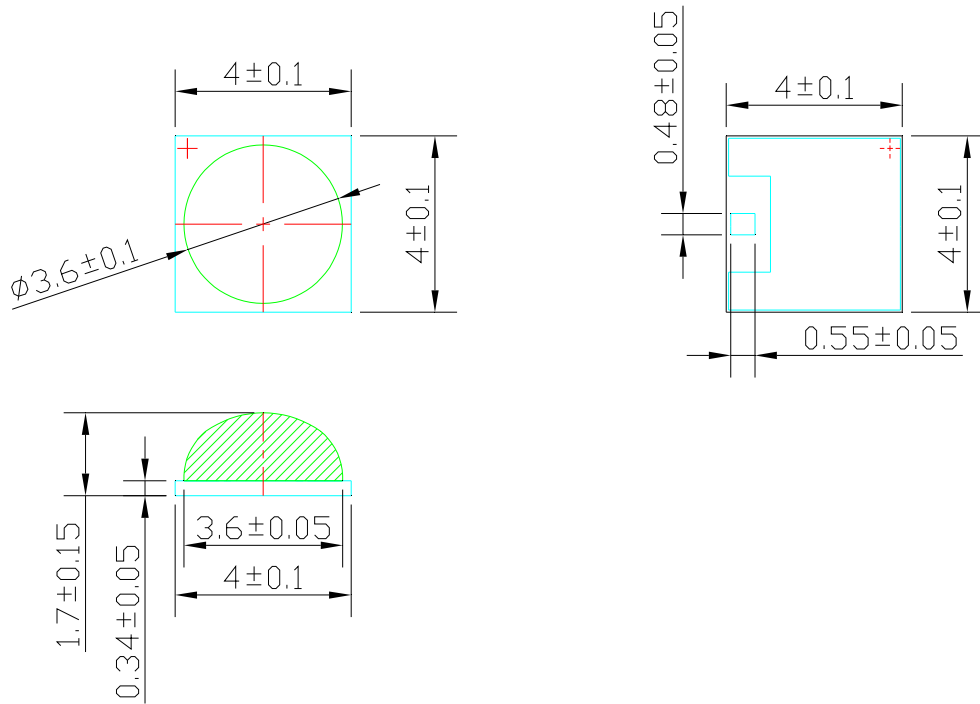

Fig.7A Package Outline Drawing.

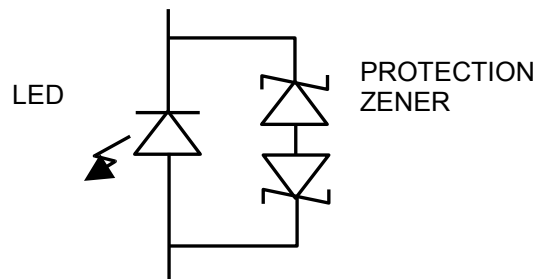
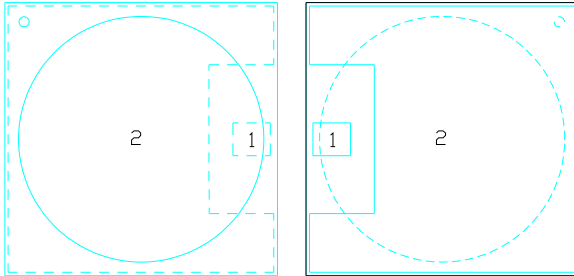

Fig. 7B Protection Circuit.

● Pad configuration



PAD	Function
1	Cathode
2	Anode
	Thermal

Fig.7C Pad configuration.

● Recommended Copper Layer Pattern

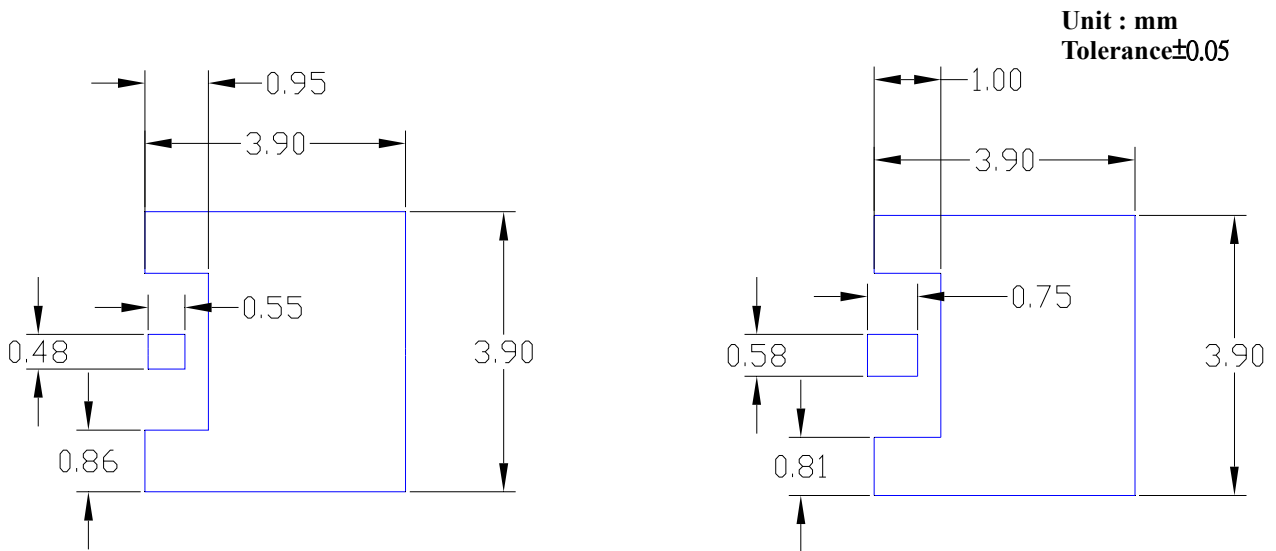

Fig.7D Solder Pad Layout.

8. Shipp **SOLDER MASK**
A. Lens Type

COPPER LAYER

(1) Tapping Dimension Packaging Specification

- 140 degree Lens Type :
 - Moisture proof bag.
 - 1 Reel/bag.

■ Q'ty: 1300(MAX)/Reel.

Unit : mm

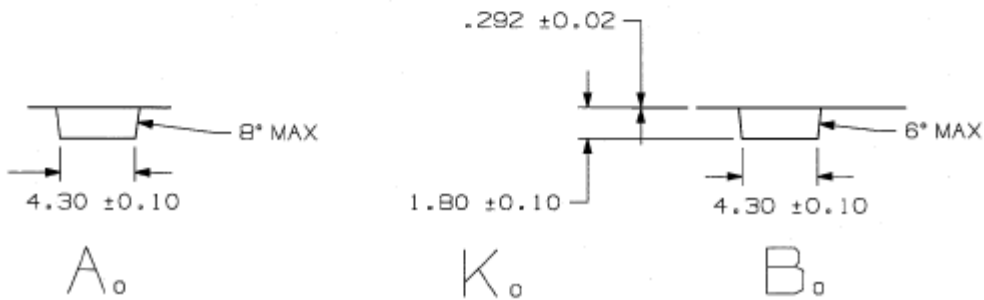
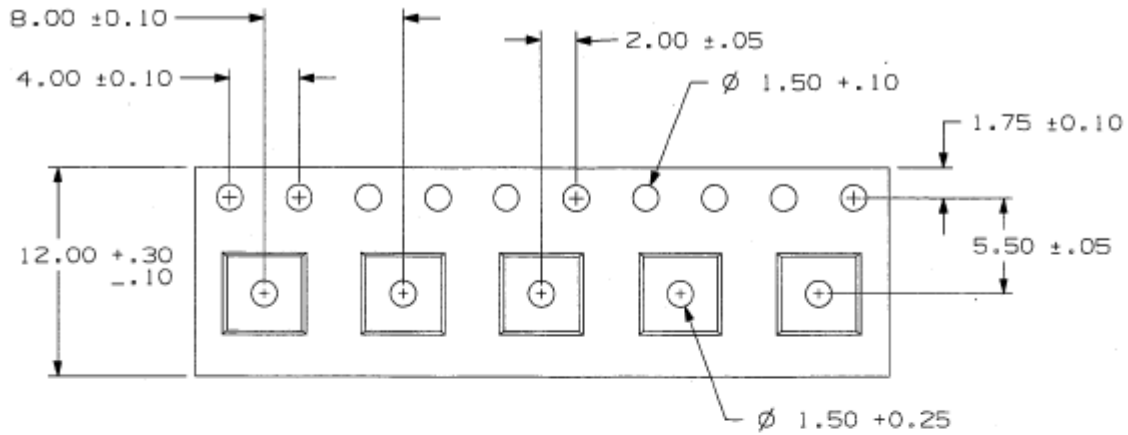

Fig.8A Carry tape Drawing.

(2) Package

Box Type	Dimension (mm)	Reel/Box	140°Lens Type(Pcs)
Small Box(S)	230x85x265	5 Reel/Box	6500
Middle Box(M)	470x265x270	30 Reel/Box	39000
Large Box(L)	470x435x270	50 Reel/Box	65000

Reel Packaging :

Reel Part :

Unit : mm

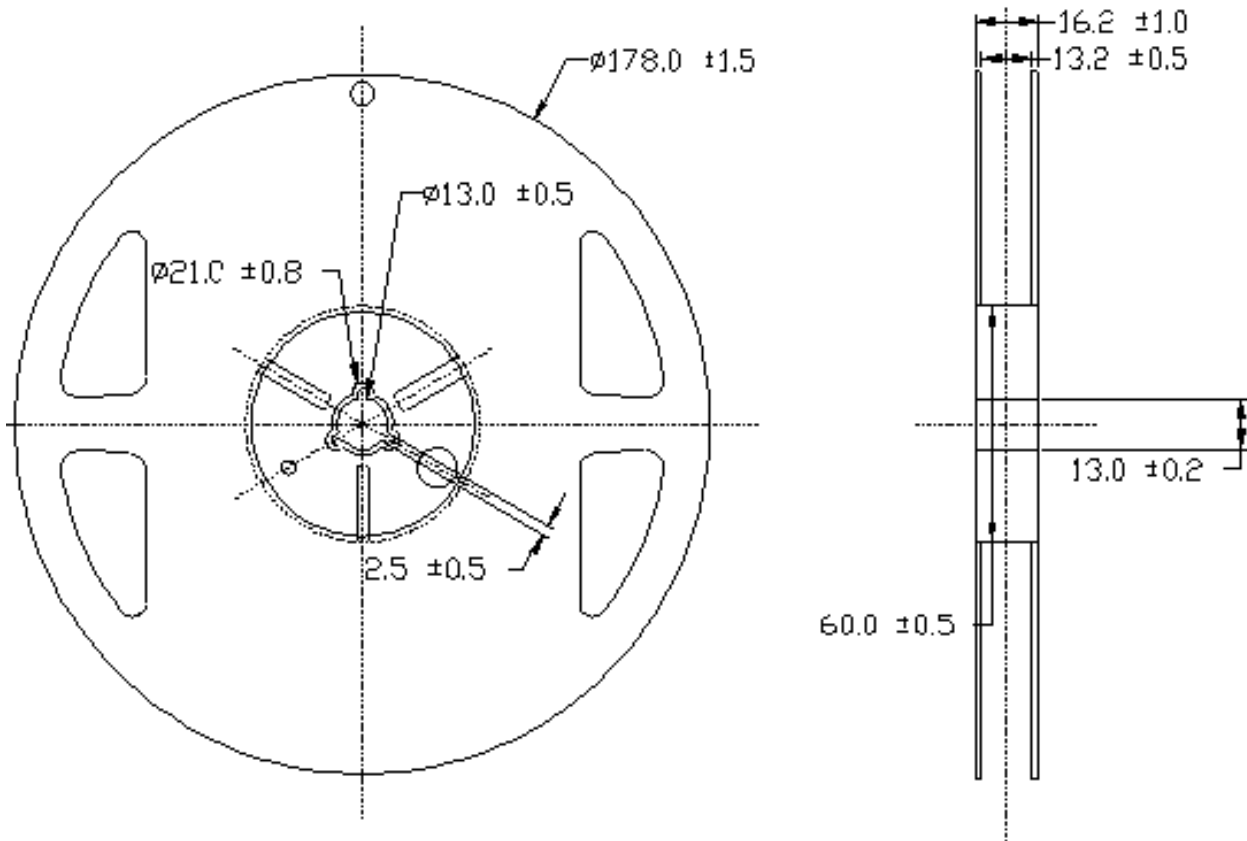
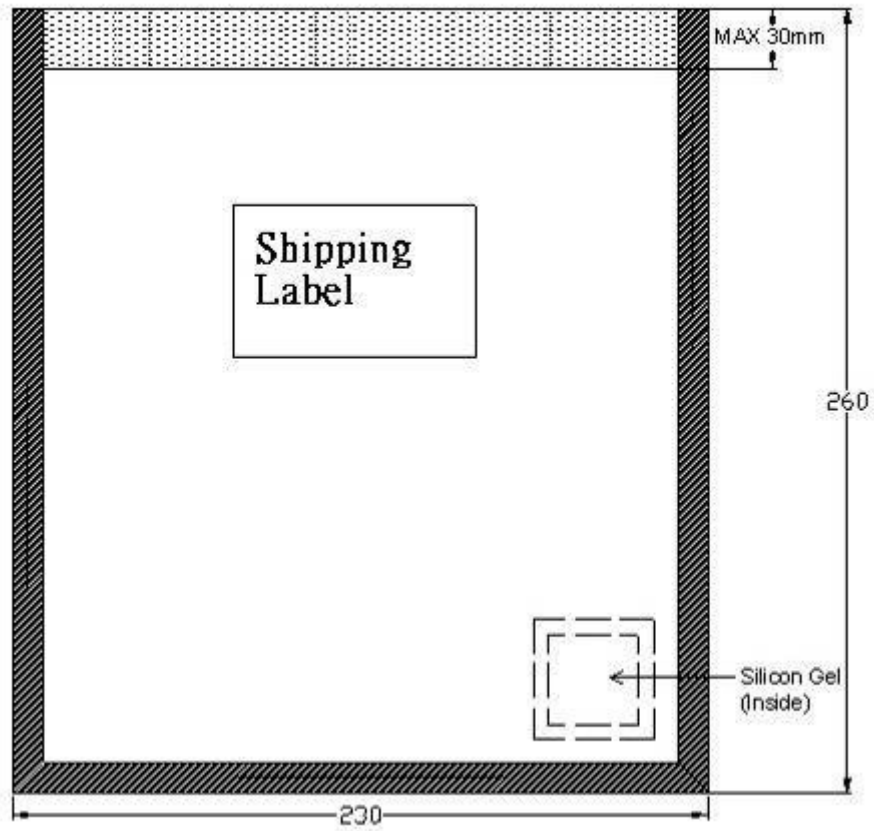

Fig.8B Reel Drawing.

Anti Statistic Bag :

Unit : mm



Small Box

Unit : mm

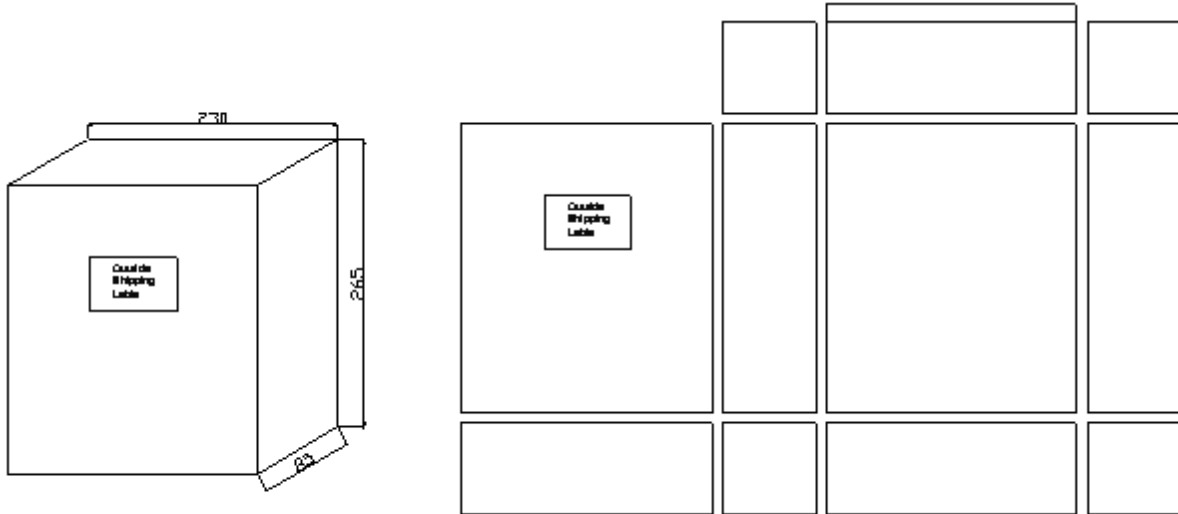

Middle Box

Unit : mm

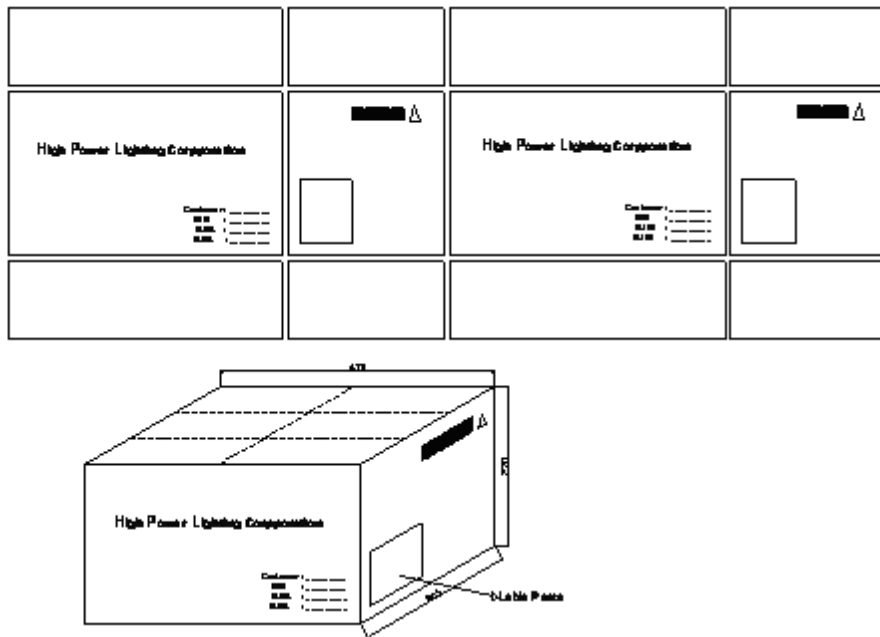

B. Assembly Type

(1) Tapping Dimension Packaging Specification

- 140 degree Assembly Type :

- Moisture proof bag.
- 21 Tray (MAX) /bag.
- Q'ty:48pcs(MAX)/Tray

Unit : mm

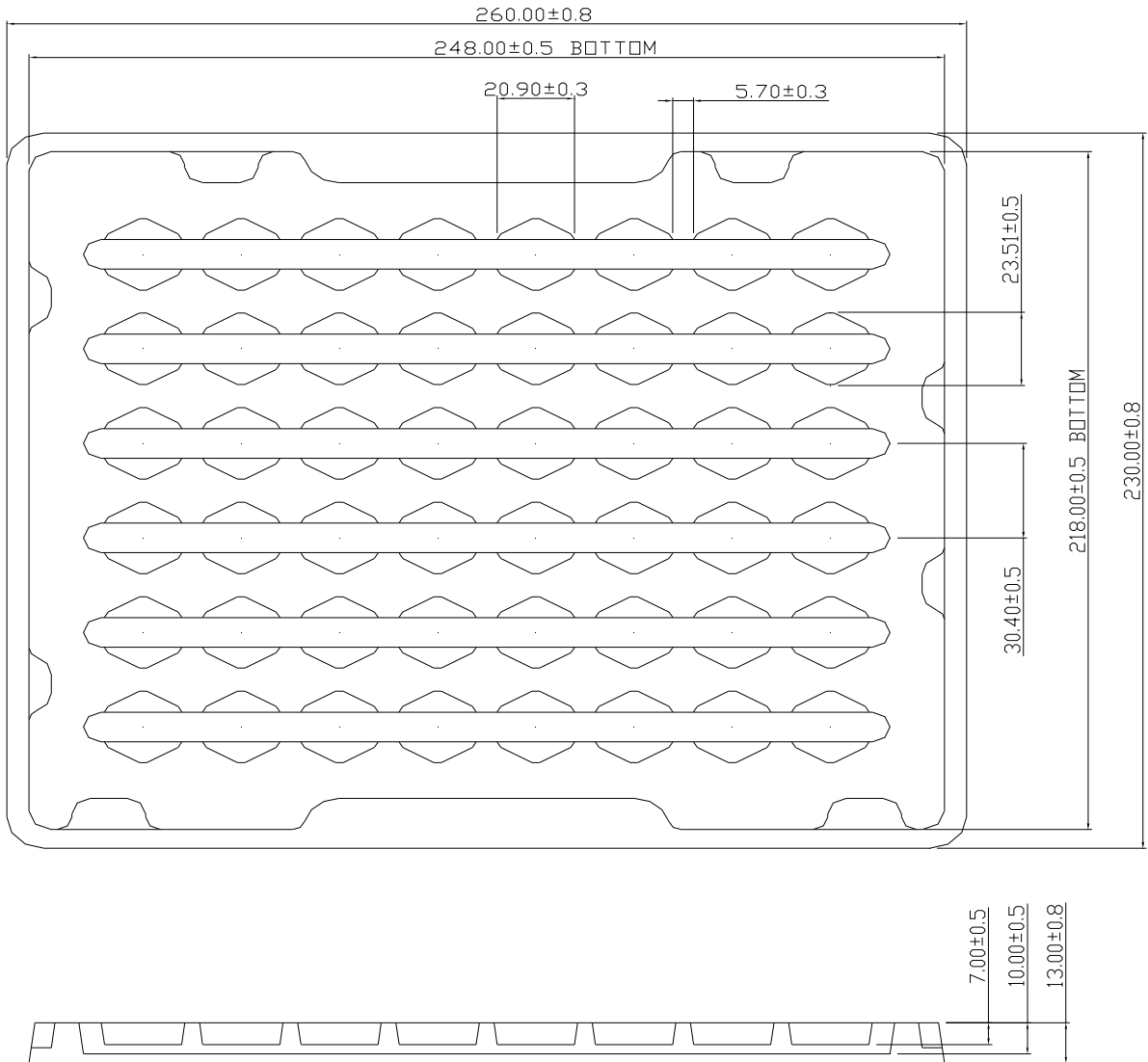

**(2) Package
Large Box**

Unit : mm

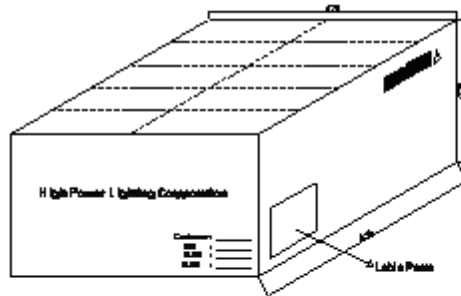
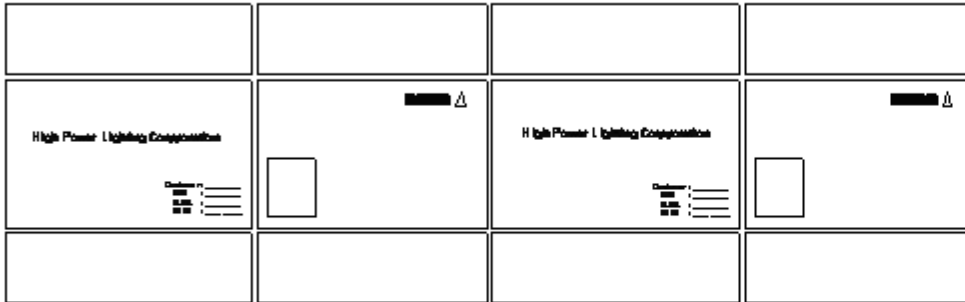

(3) Label Formation

70mm

Unit : mm

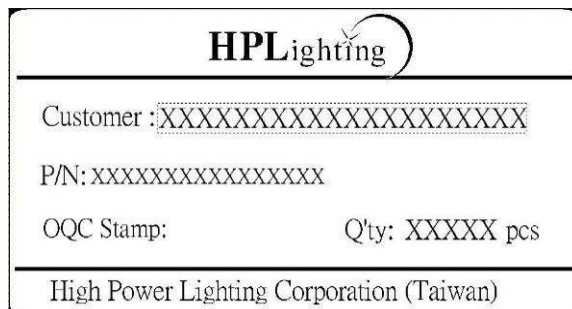
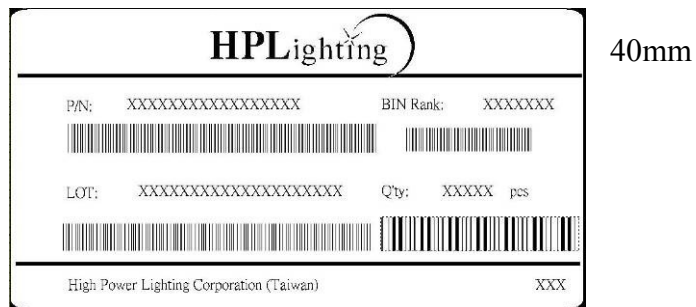

9. Recommended Solder profile

Soldering Recommended soldering conditions:

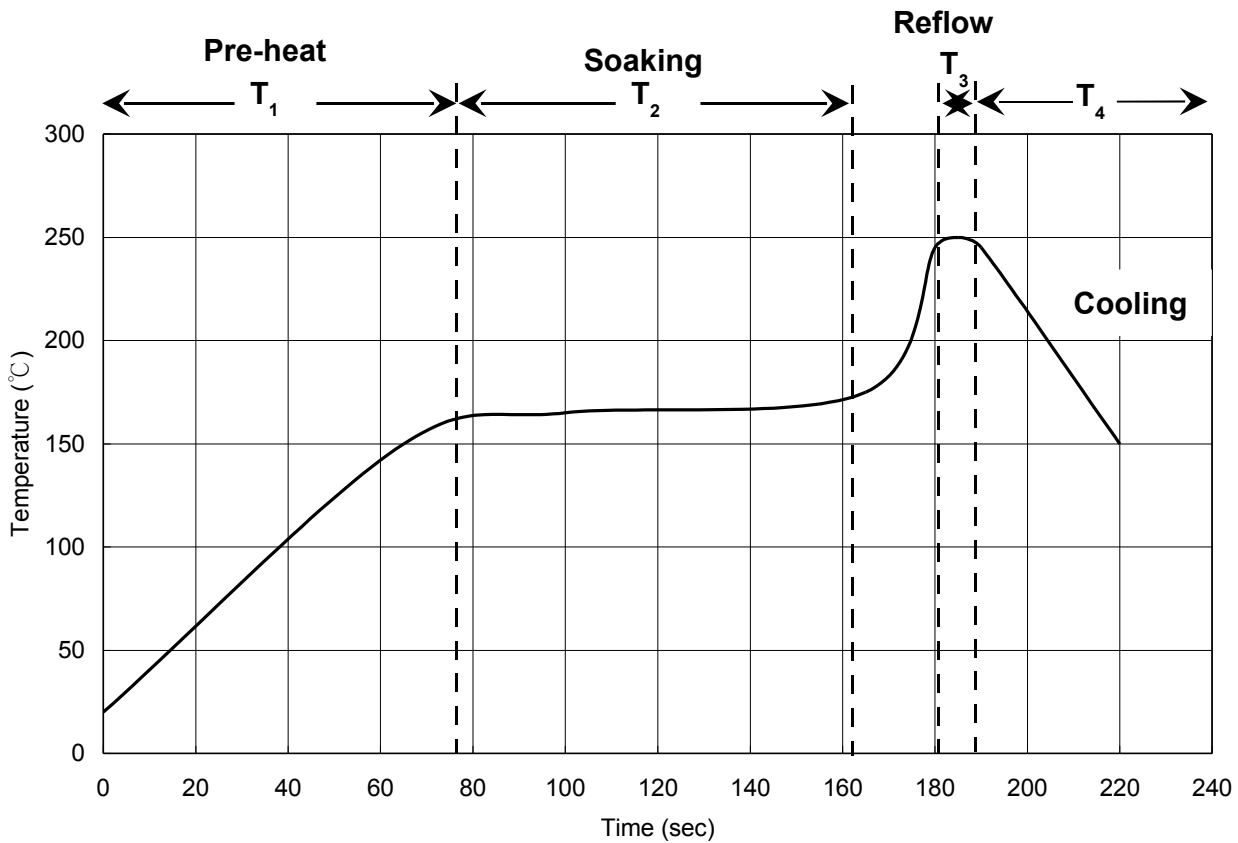

T ₁	Ramp up rate	1.0 ~ 3.0 °C/sec
	Pre-heat time	50 ~ 80 sec
T ₂	Soaking temperature	155 ~ 185 °C
	Dwell time during soaking	60 ~ 120 sec
T ₃	Reflow temperature	240 ~ 250 °C
	Reflow time	Max 10 sec
	Ramp up rate during reflow	1.2 ~ 2.3 °C/sec
T ₄	Cooling	1.0 ~ 6.0 °C/sec

Note: Suggest using Sn96Ag3Cu0.5 lead free solder.