

**6 CHANNELS ADJUSTABLE  
CONSTANT CURRENT LED DRIVER**
**DESCRIPTION**

A701/2 are adjustable constant current drivers for LED applications. Six regulated current ports are designed to provide uniform and pure DC constant current sinks for driving LEDs within a large range VF variation.

A701/2 provide users 6-channel constant current ports to match LEDs with equal current. Users may program the output current from 5mA to 40mA through an external resistor,  $R_{SET}$ , which gives user flexibility in controlling the light intensity of LEDs.

Two kinds of control logic, active high and active low, for Output Enable pin (OE/OE pin) are provided for user's varies applications. It could precisely adjust LED brightness from 0% to 100% via OE/OE pin with Pulse Width Modulation signal.

The thermal protection function protects IC from over temperature (150°C) damage. Also, the thermal pad enhances the package power dissipation.

**FEATURES**

- 6 constant-current output channels
- Output current deviations:  $\pm 3\%$  between channels,  $\pm 7\%$  between ICs.
- Output current programmable through external resistor.
- Constant output current range: 5mA~40mA
- Wide supply voltage range: 6V~50V (A702)
- 75V output sustaining voltage
- 1uA Shut-down current
- 2 kinds of control logic for Output Enable pin

**APPLICATIONS**

- Automotive Interior Lighting
- Channel Letter, Indoor Lighting
- LED Backlight Driver for MP3, MP4, Mobile Phone, Portable DVD, NB, and LCD TV.

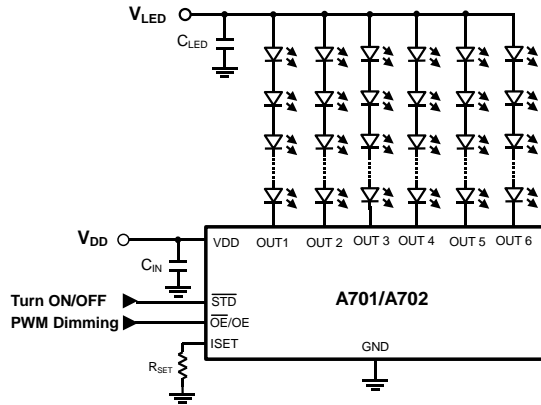
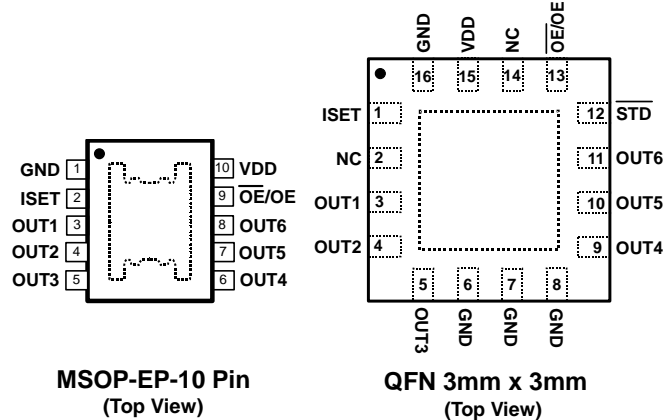
**TYPICAL APPLICATION CIRCUIT**

**PACKAGE PIN OUT**

**ORDER INFORMATION**

$V_{DD}$ Range	$\overline{OE}/OE$ Pin Logic	<b>G</b>	MSOP-EP	<b>J</b>	QFN 3x3
			10 pin		16 pin
2.9V~ 6V	Low Enable		A701GFT		A701JGT
6V~ 50V	High Enable		A702GFT-HE		A702JGT-HE
	Low Enable		A702GFT		A702JGT

Note: Part Number: A701□□□  
 A702□□□-HE

Package Type. G: MSOP-EP; J: QFN-3x3  
 Package Process. F: Lead Free; G: Green

HE: High Enable  
 T: Tape & Reel

EN Pin Logic. HE: High Enable  
 Packing. T: Tape & Reel

**PIN DESCRIPTION**

Pin Name	Pin Descriptions
GND	Ground terminal for control logic and current sink.
OUT1~OUT6	Constant current output terminals
$\overline{\text{OE}}$	Output Enable terminal, “Low” active. “Low level voltage” enables all the six output pins while “high level voltage” disables all the six output pins (blanked). It can be left floating for normally on.
OE	Output Enable terminal, “High” active. “High level voltage” enables all the six output pins while “low level voltage” disables all the six output pins (blanked). It can be left floating for normally on.
ISET	Output current set input. 1.20V is used to connect an external resistor ( $R_{\text{SET}}$ ) for setting up output current for all output channels. $I_{\text{OUTn}} = (V_{\text{SET}} / R_{\text{SET}}) \times 60$
$\overline{\text{STD}}$	Chip shutdown pin, Low active. The supply current less than 1uA when shutdown. Internal pull-high.
$V_{\text{DD}}$	6V/50V supply voltage terminal

Note: The thermal pad is suggested connect to GND on PCB. And thermal conductivity will be improved, if a copper foil on PCB is soldered with thermal pad.

**THERMAL RESISTANCE**

Package		Thermal Resistance (°C /W)	
		$\theta_{\text{JA}}$	$\theta_{\text{JT}}$
G	MSOP-EP	107	9.63
J	QFN 3x3	51	29.62

Note:

$$T_{\text{J}} = P_{\text{D}} (\theta_{\text{JC}} + \theta_{\text{CS}} + \theta_{\text{SA}}) + T_{\text{A}} = P_{\text{D}} \times \theta_{\text{JA}} + T_{\text{A}}$$

Where,  $T_{\text{J}}$ : Junction Temperature.

$T_{\text{A}}$ : Ambient Temperature.

$P_{\text{D}}$ : Dissipated power.

$\theta_{\text{JC}}$ : Thermal Resistance – Junction to Case (Tab).

$\theta_{\text{CS}}$ : Thermal Resistance – Case (Tab) to Mounting Surface

$\theta_{\text{SA}}$ : Thermal Resistance – Mounting Surface to Ambient (thermal resistance of the heat sink)

**ABSOLUTE MAXIMUM RATINGS (Note)**

Supply Voltage, $V_{DD}$	50V
$\overline{OE}/OE$ , $\overline{STD}$ Pin Input Voltage	12V
Output Current, $I_{OUTn}$	40mA
Sustaining Voltage (OUT1 ~ OUT6), $V_{DS}$	-0.4V to 75V
Maximum Operating Junction Temperature, $T_J$	125°C
Operating Temperature, $T_{opr}$	-40°C to 85°C
Storage Temperature Range	-55°C to 150°C
Lead Temperature (Soldering, 10 seconds)	260°C

Note: Exceeding these ratings could cause damage to the device. All voltages are with respect to Ground. Currents are positive into, negative out of the specified terminal.

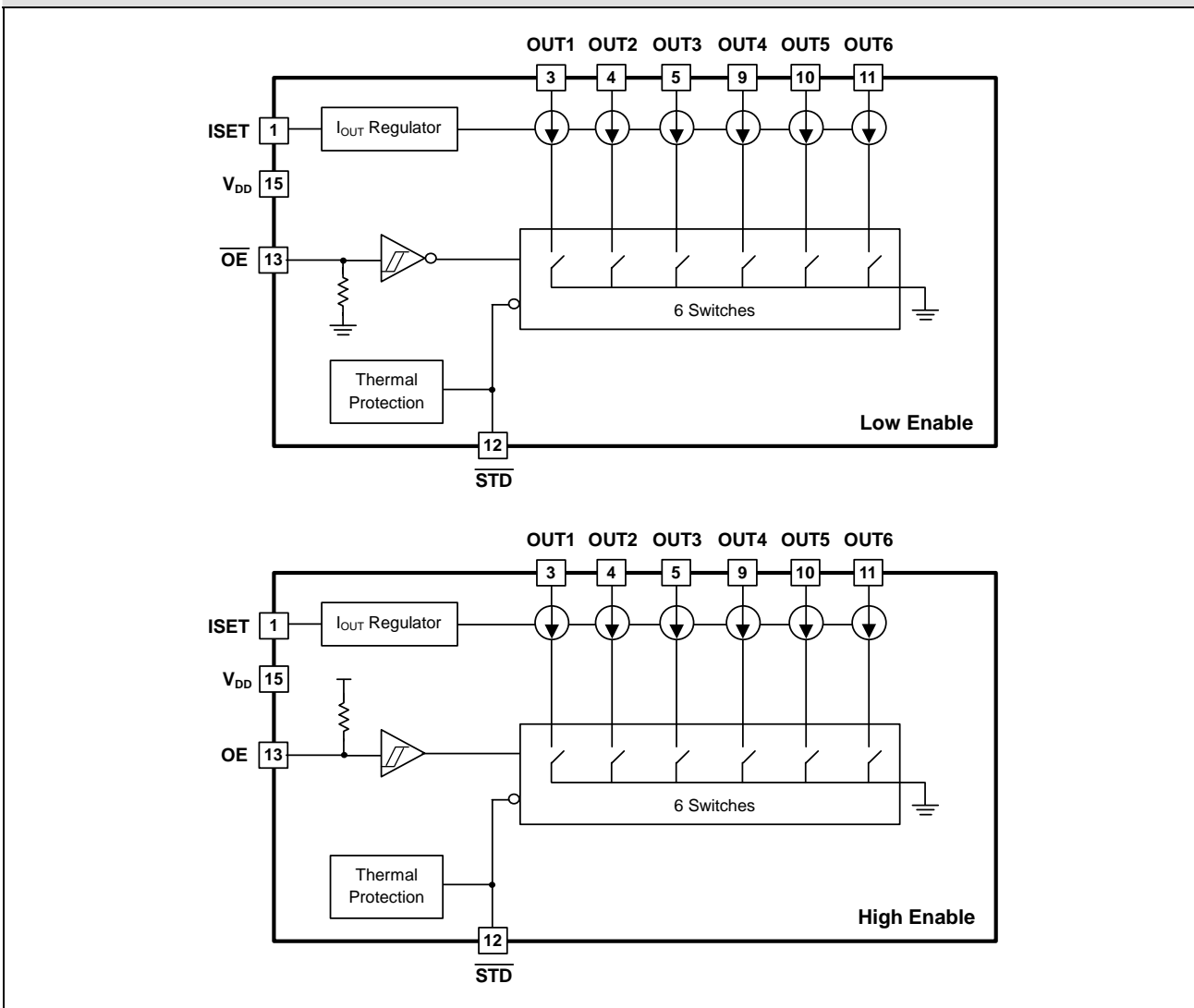
**BLOCK DIAGRAM**

**ELECTRICAL CHARACTERISTICS**

V <sub>DD</sub> =5V for A701 and V <sub>DD</sub> =12V for A702, T <sub>A</sub> =25°C. (Unless otherwise noted)							
Parameter	Symbol	Conditions	Min	Typ	Max	Unit	
Supply Voltage	V <sub>DD</sub>	A701	2.9	5	6	V	
		A702	6	12	50		
Sustaining Voltage	V <sub>DS</sub>	OUT1 ~ OUT 6			75	V	
Output Current	I <sub>OUTn</sub>	DC Test Circuit	5		40	mA	
$\overline{\text{OE}}/\text{OE}/\overline{\text{STD}}$ Input Voltage	“H” level	V <sub>IH</sub>	A701	2	6	V	
			A702	2	12		
	“L” level	V <sub>IL</sub>		GND	0.8	V	
$\overline{\text{OE}}/\text{OE}$ Input Hysteresis			200			mV	
Output Leakage Current	I <sub>OH</sub>	V <sub>OH</sub> =40V			0.5	uA	
Output Current	I <sub>OUT</sub>	V <sub>DS</sub> =0.6V, R <sub>SET</sub> =2.4k Ω	Rank A	29.1	30.0	30.9	mA
				27.9	30.0	32.1	
		V <sub>DS</sub> =0.6V, R <sub>SET</sub> =3.6k Ω	Rank A	19.4	20.0	20.6	
				18.6	20.0	21.4	
Output Current Skew	ΔI <sub>OUTn</sub>	V <sub>DS</sub> =0.6V, R <sub>SET</sub> =2.4k Ω		±1	±3	%	
		V <sub>DS</sub> =0.6V, R <sub>SET</sub> =3.6k Ω		±1	±3		
Regulation of Output Current vs. Sustaining Voltage	%/ΔV <sub>DS</sub>	V <sub>DS</sub> =0.5V ~ 3.0V		±0.1	-	%/V	
Regulation of Output Current vs. Supply Voltage	%/ΔV <sub>DD</sub>	A701, V <sub>DD</sub> = 2.9V ~ 6V		±1	-	%	
		A702, V <sub>DD</sub> = 6V ~ 40V		±1			
Pull-up Resistor, $\overline{\text{OE}}$ , $\overline{\text{STD}}$	R <sub>IN</sub> (up)		0.5	1	1.5	M Ω	
Thermal Protection Temperature	T <sub>X</sub>	When T <sub>J</sub> approaches T <sub>X</sub> and OUT is shut off		160		°C	
Thermal Protection Temperature Hysteresis				25			
Supply Current	“ON”	I <sub>DD(ON)</sub>	R <sub>SET</sub> =2.4k Ω ; $\overline{\text{OE}}/\text{OE}$ =“Active”		4	7	mA
	“OFF”	I <sub>DD(OFF)</sub>	R <sub>SET</sub> =Open; $\overline{\text{OE}}/\text{OE}$ =“Inactive”		6	9	
			R <sub>SET</sub> =2.4k Ω ; $\overline{\text{OE}}/\text{OE}$ =“Inactive”		4	7	
	Shutdown	I <sub>DD(SD)</sub>	A701, $\overline{\text{STD}}$ = “Low”		4	7	uA
A702, $\overline{\text{STD}}$ = “Low”				40	70		

**TIMING CHARACTERISTICS**

Characteristic	Symbol	Conditions	Min	Typ	Max	Unit
Propagation Delay Time (Output Current from "L" to "H")	$t_{pLH}$	$V_{DD}=5.0V(A701)$ $V_{DD}=12.0V(A702)$  $V_{DS}=1.0V$ $V_{IH}=5.0V$ $V_{IL}=GND$ $R_{SET}=2.4k\Omega$	0.1	0.3	0.6	us
Propagation Delay Time (Output Current from "H" to "L")	$t_{pHL}$		0.05	0.1	0.4	us
Shutdown Recover Delay Time				50		us
$\overline{OE}/OE$ Minimum Pulse Width	$t_{W(OE)}$		5	-	-	us
Output Current Rising Time (Turn ON, rising from 10% to 90%)	$t_{ON}$		0.5	1	2	us
Output Current falling Time (Turn OFF, falling from 90% to 10%)	$t_{OFF}$		0.5	1	2	us

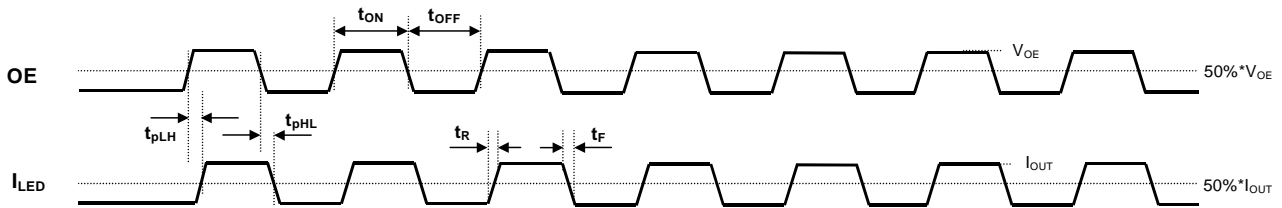
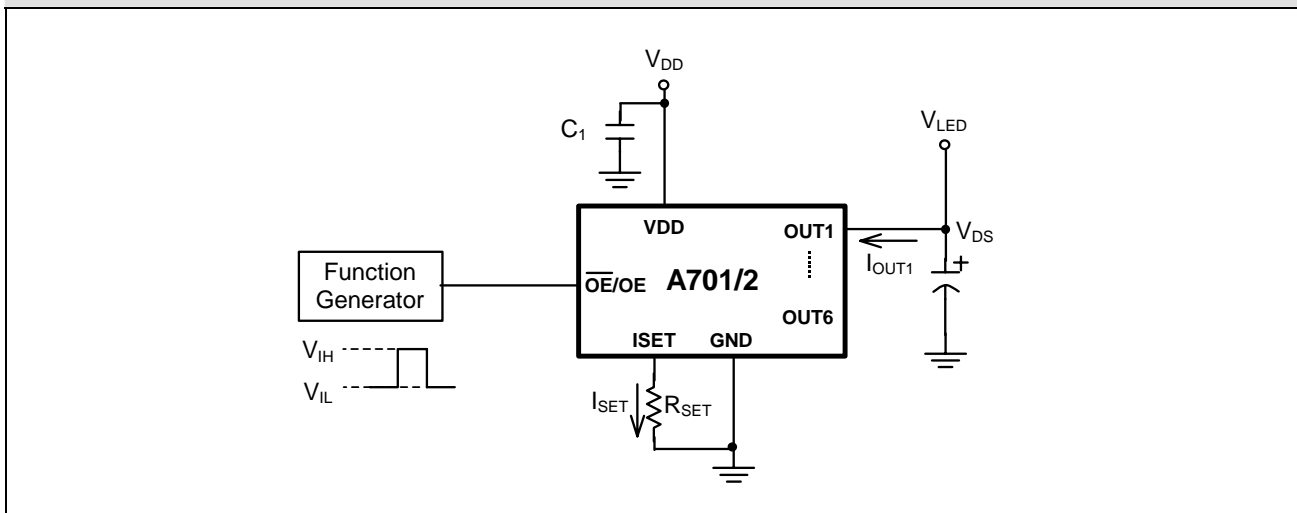
**TEST CIRCUIT FOR SWITCHING CHARACTERISTICS**

**APPLICATION INFORMATION**
**The Maximum Power Dissipation on Regulator:**

$$P_D = \sum_{n=1}^6 (V_{OUTn} \cdot I_{OUTn}) + V_{DD(MAX)} \cdot I_{DD}$$

$V_{OUTn}$  = the maximum voltage on output pin OUTn;

$I_{OUTn}$  = the nominal output current through output pin OUTn;

$V_{DD(MAX)}$  = the maximum input voltage;

$I_{DD}$  = the supply current to the regulator at  $I_{OUTn}$ ;

n = 1 ~ 6.

**Thermal Consideration:**

The A701/2 has internal power and thermal limiting circuitry designed to protect the device under overload conditions. However, maximum junction temperature ratings should not be exceeded under continuous normal load conditions. The thermal protection circuit of A701/2 prevents the device from damage due to excessive power dissipation. When the device temperature rises to approximately 150°C, the regulator will be turned off. When power consumption is over about 467mW (MSOP-10 package, at  $T_A=70^\circ\text{C}$ ) or 980mW (QFN 3x3 package, at  $T_A=70^\circ\text{C}$ ), additional heat sink is required to control the junction temperature below 120°C.

The junction temperature is:

$$T_J = P_D (\theta_{JC} + \theta_{CS} + \theta_{SA}) + T_A$$

$P_D$  : Dissipated power.

$\theta_{JC}$  : Thermal resistance from the junction to the mounting tab (case) of the package.

$\theta_{CS}$  : Thermal resistance through the interface between the IC and the surface on which it is mounted.  
(typically,  $\theta_{CS} < 1.0^\circ\text{C/W}$ )

$\theta_{SA}$  : Thermal resistance from the mounting surface to ambient (thermal resistance of the heat sink).

If PC Board copper is going to be used as a heat sink, below table can be used to determine the appropriate size of copper foil required. For multi-layered PCB, these layers can also be used as a heat sink. They can be connected with several through-hole vias.

PCB $\theta_{SA}$ ( $^\circ\text{C/W}$ )	59	45	38	33	27	24	21
PCB heat sink size ( $\text{mm}^2$ )	500	1000	1500	2000	3000	4000	5000

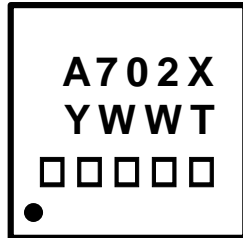
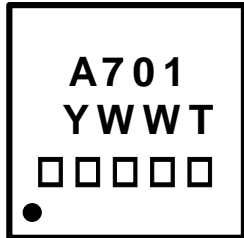
**PACKAGE**
**Top Marking for QFN 3mm x 3mm**

**X : OE Pin Control Logic**

H – HE (High Enable)

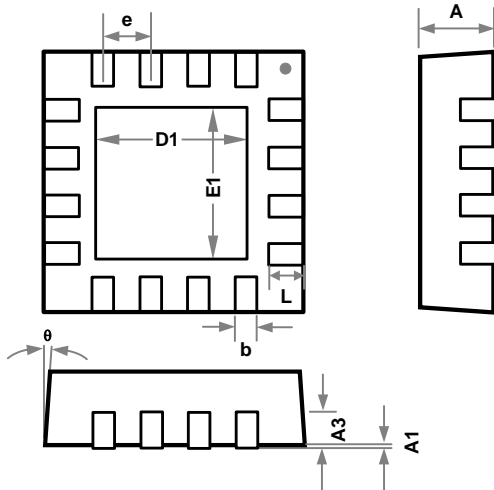
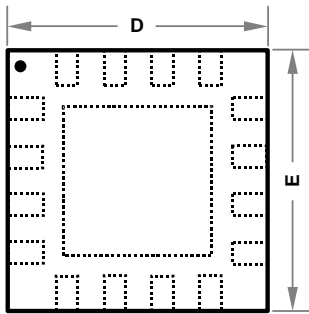
N/A – LE (Low Enable)

**Y : Year Code**
**WW : Week Code**
**T : Trace Code**
**□□□□□ : Lot Number**
**16-Pin QFN 3mmx3mm**

SYMBOLS	MIN.	TYP.	MAX.
A	0.80	0.85	0.90
A1	0	0.010	0.030
A3	-	0.20REF.	-
b	0.18	0.23	0.28
D	2.95	3.00	3.03
D1	-	1.60BSC	-
E	2.95	3.00	3.03
E1	-	1.60BSC	-
e	-	0.50BSC	-
L	0.35	0.40	0.45
$\theta^\circ$	-12	-	0

UNIT: MILLIMETERS

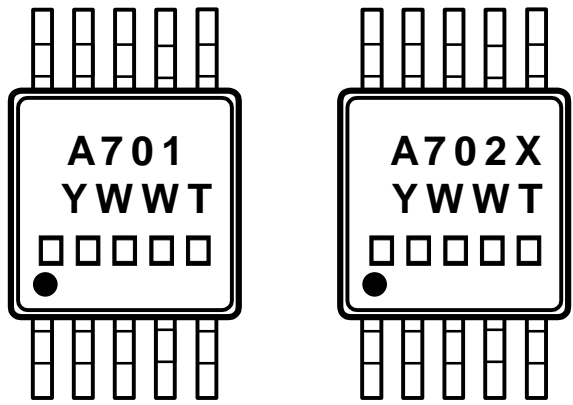
**Top Marking for MSOP-EP 10 Pin**

**X : OE Pin Control Logic**  
 H – HE (High Enable)  
 N/A – LE (Low Enable)

**Y : Year Code**

**WW : Week Code**

**T : Trace Code**

□□□□□ : Lot Number

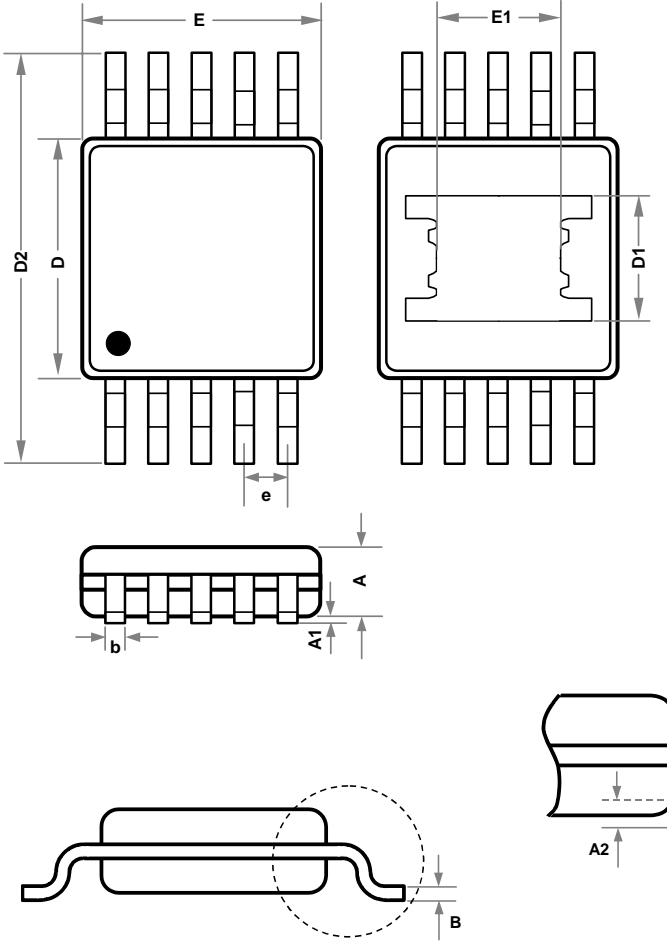
**MSOP-EP 10 Pin**

SYMBOLS	MIN.	TYP.	MAX.
A	0.81	0.86	0.91
A1	-	0.07	-
A2	-	0.25	-
B	0.10	0.15	0.20
b	0.17	-	0.27
D	2.90	3.00	3.10
D1	-	1.73	-
D2	4.68	4.88	5.08
E	2.90	3.00	3.10
E1	-	1.70	-
e	-	0.50	-
L	0.43	0.53	0.63
$\theta^\circ$	0	-	6

UNIT: MILLIMETERS

**IMPORTANT NOTICE**

ADDtek reserves the right to make changes to its products or to discontinue any integrated circuit product or service without notice, and advises its customers to obtain the latest version of relevant information to verify, before placing orders, that the information being relied on is current.

A few applications using integrated circuit products may involve potential risks of death, personal injury, or severe property or environmental damage. ADDtek integrated circuit products are not designed, intended, authorized, or warranted to be suitable for use in life-support applications, devices or systems or other critical applications. Use of ADDtek products in such applications is understood to be fully at the risk of the customer. In order to minimize risks associated with the customer's applications, the customer should provide adequate design and operating safeguards.

ADDtek assumes no liability to customer product design or application support. ADDtek warrants the performance of its products to the specifications applicable at the time of sale.

---

**ADDtek Corp.**

9F, No. 20, Sec. 3, Bade Rd., Taipei, Taiwan, 105

TEL: 2-25700299

FAX: 2-25700196

---